



ETA-Danmark A/S
Göteborg Plads 1
DK-2150 Nordhavn
Tel. +45 72 24 59 00
Fax +45 72 24 59 04
Internet www.etadanmark.dk

Authorised and notified according
to Article 29 of the Regulation (EU)
No 305/2011 of the European
Parliament and of the Council of 9
March 2011

MEMBER OF EOTA



European Technical Assessment ETA-09/0312 of 2024/03/14

General Part

Technical Assessment Body issuing the ETA and designated according to Article 29 of the Regulation (EU) No 305/2011: ETA-Danmark A/S

Trade name of the
construction product:

AV angle brackets, for types, see section 1 of this ETA

Product family to which the
above construction product
belongs:

Three-dimensional nailing plate (angle brackets, brace
connectors, hold-downs and Z-connector for timber-to-
timber connections)

Manufacturer:

August Vormann GmbH & Co. KG
Postfach 1552
Heilenbecker Strasse 191 - 205
DE-58256 Ennepetal
Tel. +49 02333 / 978 - 0
Internet www.vormann.com

Manufacturing plant:

August Vormann GmbH & Co. KG
Berliner Strasse 50
DE-04910 Elsterwerda

This European Technical
Assessment contains:

78 pages including 2 annexes which form an integral
part of the document

This European Technical
Assessment is issued in
accordance with Regulation
(EU) No 305/2011, on the
basis of:

EAD 130186-00-0603, Three Dimensional Nailing
Plates

This version replaces:

The ETA with the same number issued on 2015-07-02

Translations of this European Technical Assessment in other languages shall fully correspond to the original issued document and should be identified as such.

Communication of this European Technical Assessment, including transmission by electronic means, shall be in full (excepted the confidential Annex(es) referred to above). However, partial reproduction may be made, with the written consent of the issuing Technical Assessment Body. Any partial reproduction has to be identified as such

II SPECIFIC PART OF THE EUROPEAN TECHNICAL ASSESSMENT

1 Technical description of product

This ETA covers the following bracket types:

- 70904, 70905, 70912, 70913, 70914, 70914040, 70915, 70916, 070917, 70918, 70919, 70920, 70922, 70934, 70935, 70935020, 70936, 70937, 70938, 70940, 70941, 70942, 70943, 70944, 70945, 71084, 71085, 71086, 71086150, 71087, 71088, 71089, 71090, 71194, 71194015, 71194016 GP, 71194020, 71195, 71200
- AV brace connectors type 71107, 71108, 71109
- AV hold-downs type 71091, 71092, 71093, 071191, 71192
- AV Z-connector type 71100

AV brackets with and without rib are one-piece non-welded, face-fixed brackets to be used in timber to timber connections. They are connected to construction members made of timber or wood-based products by a range of profiled (ringed shank) nails or partially threaded screws according to EN 14592 or an ETA.

The brackets are made from pre-galvanized steel S 250 GD / Z 275 according to EN 10346:2009 with $R_{p0.2} \geq 250 \text{ N/mm}^2$, $R_m \geq 330 \text{ N/mm}^2$ or from stainless steel according to EN 10088-2:2014 with $R_{p0.2} \geq 240 \text{ N/mm}^2$ and $R_m \geq 500 \text{ N/mm}^2$ and are available with or without an embossed rib. Dimensions, hole positions and typical installations are shown in Annex A. AV brackets are made from steel with tolerances according to EN 10143.

2 Specification of the intended use in accordance with the applicable European Assessment Document (hereinafter EAD)

The brackets are intended for use in making connections in load bearing timber structures, as a connection between a beam and a purlin or a column, where requirements for mechanical resistance and stability and safety in use in the sense of the Basic Work Requirements 1 and 4 of the Regulation 305/2011 (EU) shall be fulfilled.

The connection may be with a single bracket or with an bracket on each side of the fastened timber member (see Annex A).

The static and kinematical behaviour of the timber members or the supports shall be as described in Annex B.

The wood members may be of solid timber, glued

laminated timber and similar glued members, or wood-based structural members with a characteristic density from 290 kg/m^3 to 420 kg/m^3 . This requirement to the material of the wood members can be fulfilled by using the following materials:

- Structural solid timber according to EN 14081,
- Glulam according to EN 14080,
- LVL according to EN 14374,
- Parallam PSL,
- Intrallam LSL,
- Cross laminated timber,
- Glued solid timber according to EN 14080,
- Plywood according to EN 636

Annex B states the load-carrying capacities of the bracket connections for a characteristic density of 350 kg/m^3 . For timber or wood based material with a lower characteristic density than 350 kg/m^3 the load-carrying capacities shall be reduced by the k_{dens} factor:

$$k_{\text{dens}} = \left(\frac{\rho_k}{350} \right)^2$$

Where ρ_k is the characteristic density of the timber in kg/m^3 .

The design of the connections shall be in accordance with Eurocode 5 or a similar national Timber Code. The wood members shall have a thickness which is larger than the penetration depth of the fasteners into the members.

The brackets are primarily for use in timber structures subject to the dry, internal conditions defined by service classes 1 and 2 of Eurocode 5 and for connections subject to static or quasi-static loading.

The brackets can also be used in outdoor timber structures, service class 3, when a corrosion protection in accordance with Eurocode 5 is applied, or when stainless steel with similar or better characteristic yield and ultimate strength is employed.

To avoid contact corrosion, stainless steel brackets shall be used with fasteners made from stainless steel.

The scope of the connectors regarding resistance to corrosion shall be defined according to national provisions that apply at the installation site considering environmental conditions and in conjunction with the admissible service conditions according to EN 1995-1-1 and the admissible corrosivity category as described and defined in EN ISO 12944-2.

The angle brackets, brace connectors and Z-connector are used for timber to timber connections. The hold-downs are used for connections between a timber member and a member of concrete.

Assumed working life

The assumed intended working life of the brackets for the intended use is 50 years, provided that they are subject to appropriate use and maintenance.

The information on the working life should not be regarded as a guarantee provided by the manufacturer or ETA Danmark. An “assumed intended working life” means that it is expected that, when this working life has elapsed, the real working life may be, in normal use conditions, considerably longer without major degradation affecting the essential requirements.

3 Performance of the product and references to the methods used for its assessment

Characteristic	Assessment of characteristic
3.1 Mechanical resistance and stability*) (BWR1)	
Joint Strength - Characteristic load-carrying capacity	See Annex B
Joint Stiffness	See Annex B
Joint ductility	No performance assessed
Resistance to seismic actions	No performance assessed
Resistance to corrosion and deterioration	See section 3.6
3.2 Safety in case of fire (BWR2)	
Reaction to fire	The brackets are made from steel classified as Euroclass A1 in accordance with EN 13501-1 and Commission Delegated Regulation 2016/364
Resistance to fire	No performance assessed
3.3 General aspects related to the performance of the product	
	The brackets have been assessed as having satisfactory durability and serviceability when used in timber structures using the timber species described in Eurocode 5 and subject to the conditions defined by service class 1 and 2

*) See additional information in section 3.4 – 3.7.

3.4 Methods of verification

Safety principles and partial factors

The characteristic load-carrying capacities are based on the characteristic values of the nail connections and the steel plates. To obtain design values the capacities have to be divided by different partial factors for the material properties, the nail connection in addition multiplied with the coefficient k_{mod} .

According to EN 1990 (Eurocode – Basis of design) paragraph 6.3.5 the design value of load-carrying capacity may be determined by reducing the characteristic values of the load-carrying capacity with different partial factors.

Thus, the characteristic values of the load-carrying capacity are determined also for timber failure $F_{\text{Rk,H}}$ (obtaining the embedment strength of fasteners subjected to shear or the withdrawal capacity of the most loaded nail, respectively) as well as for steel plate failure $F_{\text{Rk,S}}$. The design value of the load-carrying capacity is the smaller value of both load-carrying capacities.

$$F_{\text{Rd}} = \min \left\{ \frac{k_{\text{mod}} \cdot F_{\text{Rk,H}}}{\gamma_{\text{M,H}}}, \frac{F_{\text{Rk,S}}}{\gamma_{\text{M,S}}} \right\}$$

Therefore, for timber failure the load duration class and the service class are included. The different partial factors γ_{M} for steel or timber, respectively, are also correctly taken into account.

3.5 Mechanical resistance and stability

See annex B for the characteristic load-carrying capacity in the different directions F_1 to F_5 .

The characteristic capacities of the brackets are determined by calculation assisted by testing as described in EAD 130186-00-0603 clause 2.2.1. They should be used for designs in accordance with Eurocode 5 or a similar national Timber Code.

Threaded nails (ringed shank nails) in accordance to EN 14592 or an ETA

In the formulas in Annex B the capacities for threaded nails calculated from the formulas of Eurocode 5 are used assuming a thick steel plate when calculating the lateral nail load-carrying-capacity.

The load bearing capacities of the brackets (except angle bracket type 071 200 000) has been determined based on the use of connector nails 4,0 x 40 mm in accordance with the German national specification for the nails.

The shape of the nail directly under the head shall be in the form of a truncated cone with a diameter under the nail head which exceeds the hole diameter.

Partially threaded screws in accordance to EN 14592

In the formulas in Annex B the capacities for threaded screws calculated from the formulas of Eurocode 5 are used assuming a thin steel plate when calculating the lateral screw load-carrying-capacity.

The load bearing capacities of the angle bracket type 071 200 000 has been determined based on the use of connector screws 4,5 x 40 mm.

The design models allow the use of fasteners described in the Table A.4 on page 13 in Annex A.

No performance has been determined in relation to ductility of a joint under cyclic testing. The contribution to the performance of structures in seismic zones, therefore, has not been assessed.

No performance has been determined in relation to the joint's stiffness properties - to be used for the analysis of the serviceability limit state.

3.6 Aspects related to the performance of the product

Corrosion protection in service class 1 and 2.

In accordance with EAD 130186-00-0603 the brackets are made from pre-galvanized steel S 250 GD / Z 275 according to EN 10346:2009 with $R_{\text{p}0,2} \geq 250 \text{ N/mm}^2$, $R_{\text{m}} \leq 330 \text{ N/mm}^2$ or from stainless steel according to EN 10088-2:2014 $R_{\text{p}0,2} \geq 240 \text{ N/mm}^2$ and $R_{\text{m}} \geq 500 \text{ N/mm}^2$.

Corrosion protection in service class 3.

In accordance with EAD 130186-00-0603 the brackets are made from stainless steel according to EN 10088-2:2014 with $R_{\text{p}0,2} \geq 240 \text{ N/mm}^2$ and $R_{\text{m}} \geq 500 \text{ N/mm}^2$.

3.7 General aspects related to the use of the product

AV brackets are manufactured in accordance with the provisions of this European Technical Assessment using the manufacturing processes as identified in the inspection of the plant by the notified inspection body and laid down in the technical documentation

AV brackets

The following provisions concerning installation apply:

The structural members – the components 1 and 2 shown in the figure on page 77 - to which the brackets are fixed shall be:

- Restrained against rotation. At a load F_4/F_5 and arrangement of two brackets per connection, the component 2 is allowed to be restrained against rotation by the Brackets.
- Strength class C14 or better, see section 1 of this ETA
- Free from wane under the bracket.

- The actual end bearing capacity of the timber member to be used in conjunction with the bracket is checked by the designer of the structure to ensure it is not less than the bracket capacity and, if necessary, the bracket capacity reduced accordingly.
- The gap between the timber members does not exceed 3 mm.
- There are no specific requirements relating to preparation of the timber members.

The execution of the connection shall be in accordance with the approval holder's technical literature.

4 Assessment and verification of constancy of performance (hereinafter AVCP) system applied, with reference to its legal base

4.1 AVCP system

According to the decision 97/638/EC of the European Commission¹, as amended, the system(s) of assessment and verification of constancy of performance (see Annex V to Regulation (EU) No 305/2011) is 2+.

5 Technical details necessary for the implementation of the AVCP system, as provided for in the applicable EAD

Technical details necessary for the implementation of the AVCP system are laid down in the control plan deposited at ETA-Danmark

Issued in Copenhagen on 2024-03-14 by



Thomas Bruun
Managing Director, ETA-Danmark

Annex A
Product details and definitions

Table A.1 Materials specification

Bracket number	Bracket type	Thickness (mm)	Steel specification	Coating specification
070 904 000	40x40x40	2,0	S250GD/stainless steel	Z 275 / -
070 905 000	50x50x40	2,0	S250GD/stainless steel	Z 275 / -
070 912 000	60x40x60	2,5	S250GD	Z 275
070 913 000	80x60x60	2,5	S250GD	Z 275
070 914 000	100x60x60	2,5	S250GD	Z 275
070 914 040	100x60x40	2,5	S250GD	Z 275
070 915 000	90x60x60	2,5	S250GD	Z 275
070 916 000	60x35x60	2,5	S250GD	Z 275
070 917 000	120x90x40	4,0	S250GD	Z 275
070 918 000	90x35x40	2,5	S250GD	Z 275
070 919 000	110x35x40	2,5	S250GD	Z 275
070 920 000	140x35x40	2,5	S250GD	Z 275
070 922 000	52x52x40	2,5	S250GD	Z 275
070 934 000	40x40x60	2,0	stainless steel	-
070 934 000	40x40x60	2,5	S250GD/ stainless steel	Z 275
070 935 000	60x60x40	2,0	stainless steel	-
070 935 000	60x60x40	2,5	S250GD/ stainless steel	Z 275 / -
070 935 020	60x60x40	2,0	S250GD	Z 275
070 936 000	60x60x50	2,5	S250GD	Z 275
070 937 000	60x60x60	2,0	stainless steel	-
070 937 000	60x60x60	2,5	S250GD/ stainless steel	Z 275 / -
070 938 000	60x60x80	2,5	S250GD	Z 275
070 940 000	80x80x60	2,5	S250GD	Z 275
070 941 000	80x80x80	2,5	S250GD	Z 275
070 942 000	70x50x40	2,0	S250GD	Z 275
070 943 000	100x100x60	2,5	S250GD	Z 275
070 944 000	100x100x80	2,5	S250GD	Z 275
070 945 000	100x100x100	2,5	S250GD	Z 275
071 084 000	75x75x40	2,0	S250GD	Z 275
071 085 000	100x100x40	2,0	S250GD	Z 275
071 086 000	125x125x40	2,0	S250GD	Z 275
071 086 150	150x150x65	2,5	S250GD	Z 275
071 087 000	42x42x100	2,0	S250GD	Z 275
071 088 000	42x42x160	2,0	S250GD	Z 275
071 089 000	60x60x100	2,5	S250GD	Z 275
071 090 000	80x80x100	2,5	S250GD	Z 275

071 091 000	202x42x40	2,0	S250GD	Z 275
071 092 000	302x42x40	2,0	S250GD	Z 275
071 093 000	402x42x40	2,0	S250GD	Z 275
071 100 000	33x43x83x54	3,0	S250GD	Z 275
071 107 000	70x70x55	2,5	S250GD	Z 275
071 108 000	90x90x65	2,5	S250GD	Z 275
071 109 000	88x88x40	2,5	stainless steel	-
071 191 000	204x44x40	4,0	S250GD	Z 275
071 192 000	304x44x40	4,0	S250GD	Z 275
071 194 000	90x48x48	3,0	S250GD	Z 275
071 194 015	75x48x65	1,5	S250GD	Z 275
071 194 016 GP	75x48x65	1,5	S250GD	Z 275
071 194 020	75x48x65	2,0	S250GD	Z 275
071 195 000	90x48x76	3,0	S250GD	Z 275
071 200 000	52x37x70	2,0	stainless steel	-

Table A.2 Range of sizes

Bracket number	Bracket type	Height (mm) vertical		Height (mm) horizontal		Width (mm)	
		min	max	min	max	min	max
070 904 000	40x40x40	39,4	40,6	39,4	40,6	39,4	40,6
070 905 000	50x50x40	49,4	50,6	49,4	50,6	39,4	40,6
070 912 000	60x40x60	59,4	60,6	39,4	40,6	59,4	60,6
070 913 000	80x60x60	79,2	80,8	59,4	60,6	59,4	60,6
070 914 000	100x60x60	99,2	100,8	59,4	60,6	59,4	60,6
070 914 040	100x60x40	99,2	100,8	59,4	60,6	39,4	40,6
070 915 000	90x60x60	89,2	90,8	59,4	60,6	59,4	60,6
070 916 000	60x35x60	59,4	60,6	34,4	35,6	59,4	60,6
070 917 000	120x90x40	119,2	120,8	89,2	90,8	39,4	40,6
070 918 000	90x35x40	89,2	90,8	34,4	35,6	39,4	40,6
070 919 000	110x35x40	109,2	110,8	34,4	35,6	39,4	40,6
070 920 000	140x35x40	139,2	140,8	34,4	35,6	39,4	40,6
070 922 000	52x52x40	51,4	52,6	51,4	52,6	39,4	40,6
070 934 000	40x40x60	39,4	40,6	39,4	40,6	59,4	60,6
070 935 000	60x60x40	59,4	60,6	59,4	60,6	39,4	40,6
070 935 020	60x60x40	59,4	60,6	59,4	60,6	39,4	40,6
070 936 000	60x60x50	59,4	60,6	59,4	60,6	49,4	50,6
070 937 000	60x60x60	59,4	60,6	59,4	60,6	59,4	60,6
070 938 000	60x60x80	59,4	60,6	59,4	60,6	79,2	80,8
070 940 000	80x80x60	79,2	80,8	79,2	8,8	59,4	60,6
070 941 000	80x80x80	79,2	80,8	79,2	80,8	79,2	80,8
070 942 000	70x50x40	69,2	49,4	49,4	50,6	39,4	40,6
070 943 000	100x100x60	99,2	100,8	99,2	100,8	59,4	60,6
070 944 000	100x100x80	99,2	100,8	99,2	100,8	79,2	80,8
070 945 000	100x100x100	99,2	100,8	99,2	100,8	99,2	100,8
071 084 000	75x75x40	74,2	75,8	74,2	75,8	39,4	40,6
071 085 000	100x100x40	99,2	100,8	99,2	100,8	39,4	40,6
071 086 000	125x125x40	124,2	125,8	124,2	125,8	39,4	40,6
071 086 150	150x150x65	149,2	150,8	149,2	150,8	64,4	65,6
071 087 000	42x42x100	41,4	42,6	41,4	42,6	99,2	100,8
071 088 000	42x42x160	41,4	42,6	41,4	42,6	159,2	160,8
071 089 000	60x60x100	59,4	60,6	59,4	60,6	99,2	100,8
071 090 000	80x80x100	79,2	80,8	79,2	80,8	99,2	100,8

071 091 000	202x42x40	198,8	201,2	41,4	42,6	39,4	40,6
071 092 000	302x42x40	298,8	301,2	41,4	42,6	39,4	40,6
071 093 000	402x42x40	398,8	401,2	41,4	42,6	39,4	40,6
071 107 000	70x70x55	69,2	70,8	69,2	70,8	54,4	55,6
071 108 000	90x90x65	89,2	90,8	89,2	90,8	64,2	65,8
071 109 000	88x88x40	87,2	88,8	87,2	88,8	39,4	40,6
071 191 000	204x44x40	198,8	201,2	43,2	44,8	39,2	40,8
071 192 000	304x44x40	298,8	301,2	43,2	44,8	39,2	40,8
071 091 000	202x42x40	198,8	201,2	41,4	42,6	39,4	40,6
071 194 000	90x48x48	89,2	90,8	47,4	48,6	47,4	48,6
071 194 015	75x48x65	74,2	75,8	47,4	48,6	64,2	65,8
071 194 016 GP	75x48x65	298,8	301,2	43,4	44,6	39,4	40,6
071 194 020	75x48x65	74,2	75,8	47,4	48,6	64,2	65,8
071 195 000	90x48x76	89,2	90,8	47,4	48,6	75,2	76,8
071 200 000	52x37x70	51,4	52,6	36,4	37,6	69,2	70,8

Table A.3: Range of sizes Z-connector

Bracket number	Bracket type	Height (mm) horizontal (top)		Height (mm) vertical		Height (mm) horizontal (bottom)		Width (mm)	
		min	max	min	max	min	max	min	max
071100000	33x43x83x54	32,4	33,6	42,4	43,6	82,2	83,8	53,4	54,6

Table A.4 Fastener specification

Fastener type	Fastener size (mm)			Finish
	Diameter	Length	Threaded length	
According to EN 14592 or ETA				
Threaded nail	4,0	40	31	Electroplated zinc / stainless steel
Partially threaded screw	4,5	40	27	Electroplated zinc / stainless steel
The shape of the nail directly under the head shall be in the form of a truncated cone with a diameter under the nail head which exceeds the hole diameter.				

AV Brackets

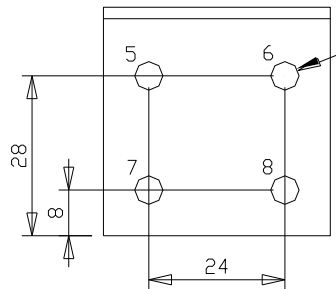
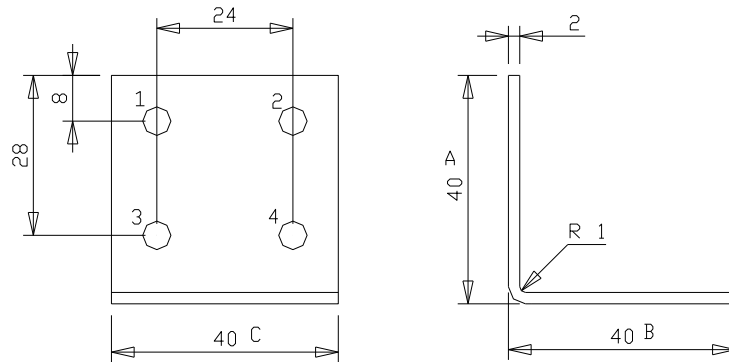

R2.5x \varnothing 5mm

August Vormann
GmbH&Co.KG
Heilenbeckerstr.
58256 Ennepetal

Winkelverbinder
70904

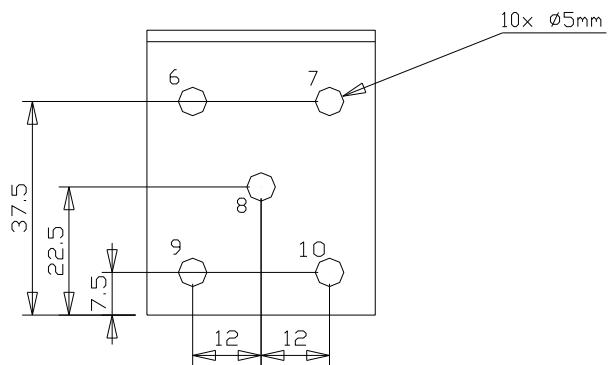
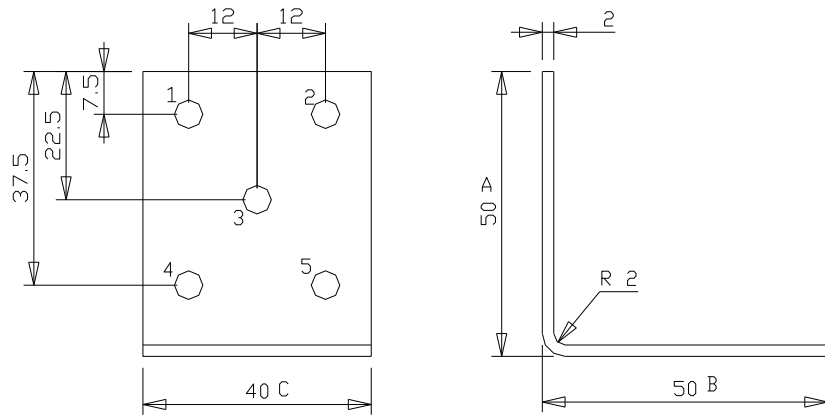

<p>August Vormann GmbH&Co.KG Heilenbeckerstr. 58256 Ennepetal</p>	<p>Winkelverbinder 70905</p>	
---	----------------------------------	--

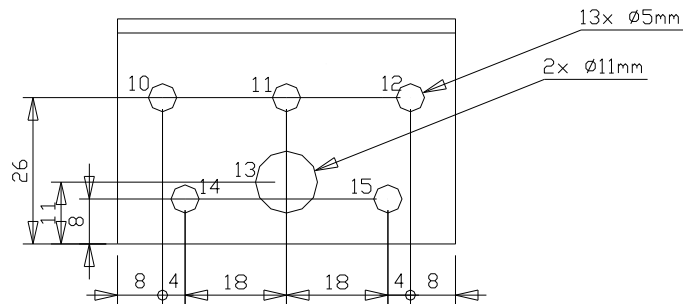
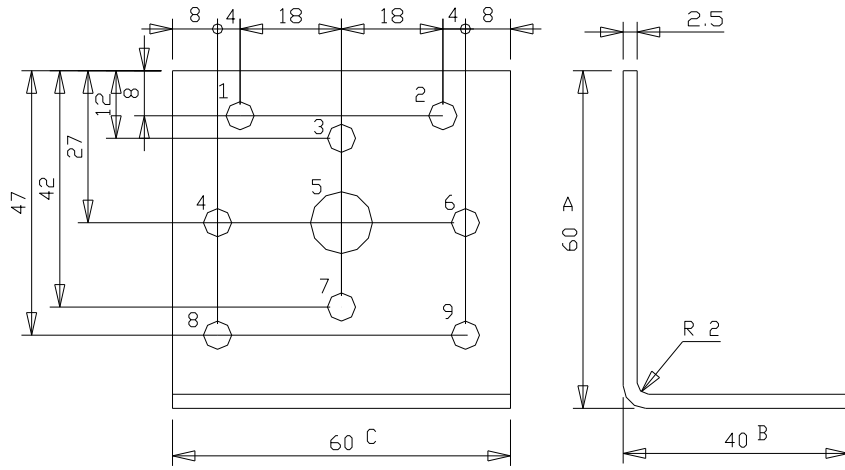

August Vormann
 GmbH&Co.KG
 Heilenbeckerstr.
 58256 Ennepetal

Winkelverbinder
 70912

Speicher Code: /z/hv1/70912so

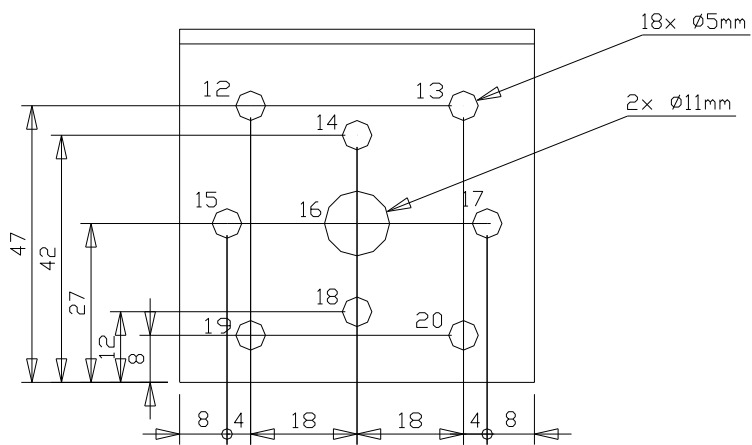
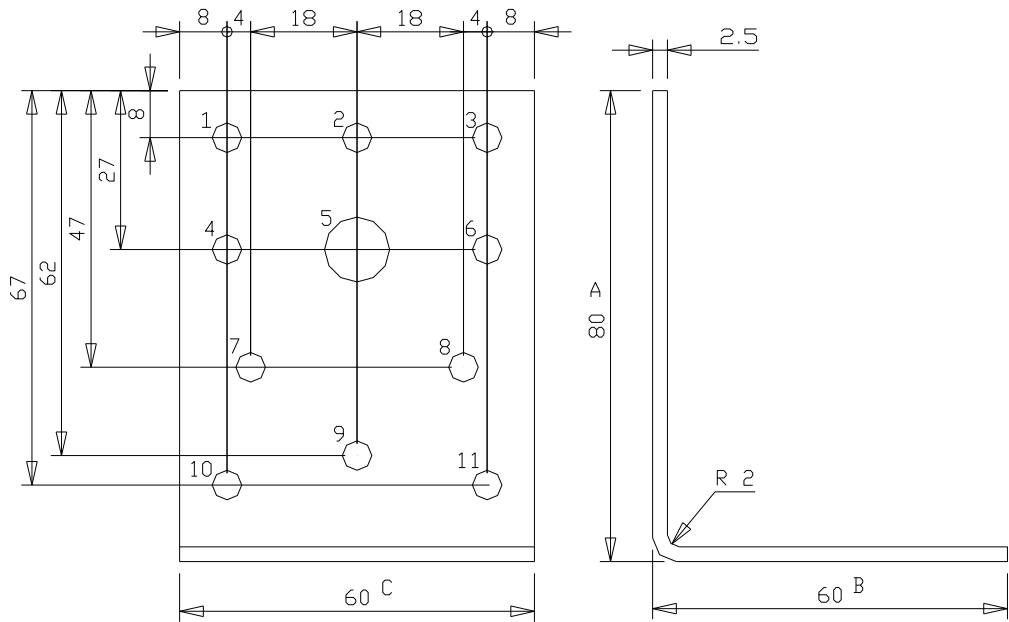

August Vormann
 GmbH&Co.KG
 Heilenbeckerstr.
 58256 Ennepetal

Winkelverbinder
 70913

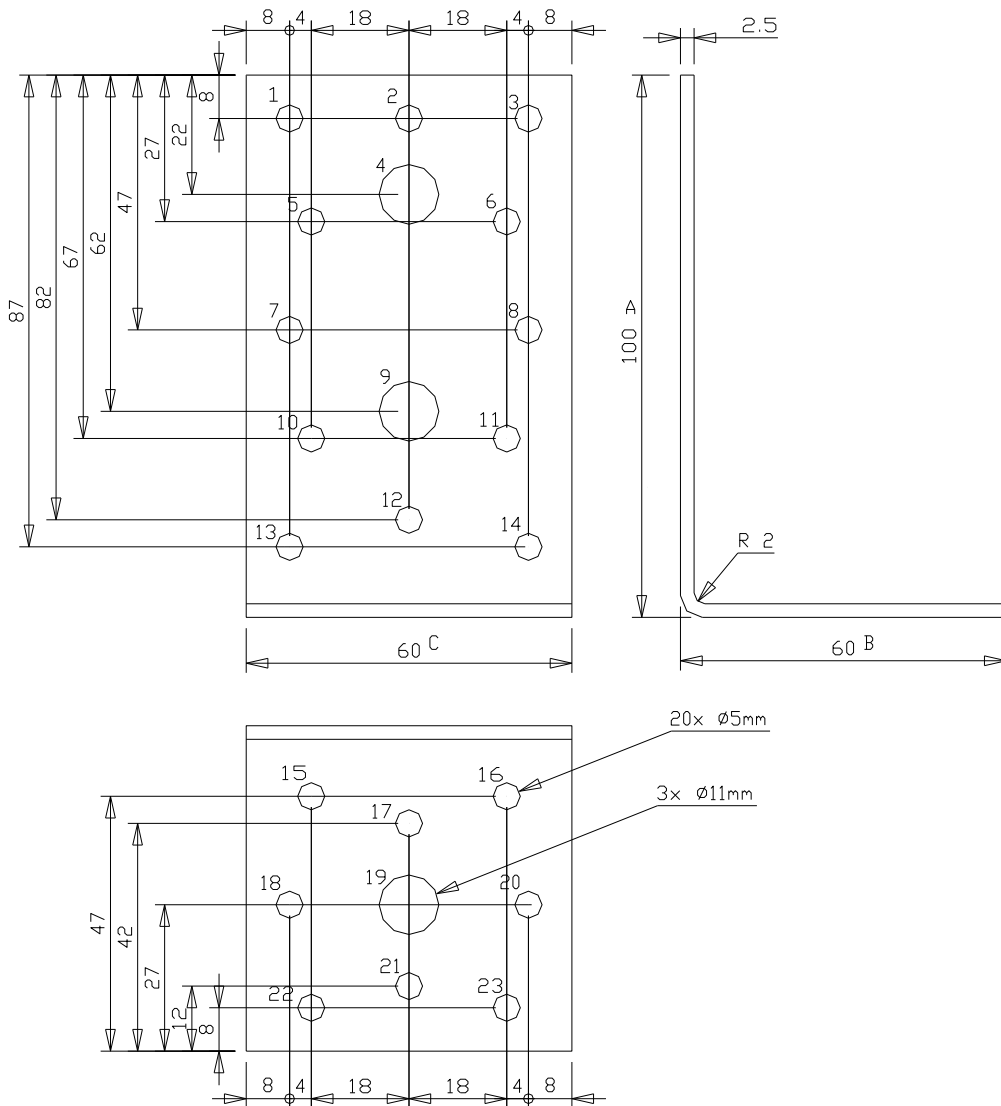

August Vormann
 GmbH&Co.KG
 Heilenbeckerstr.
 58256 Ennepetal

Winkelverbinder
 70914

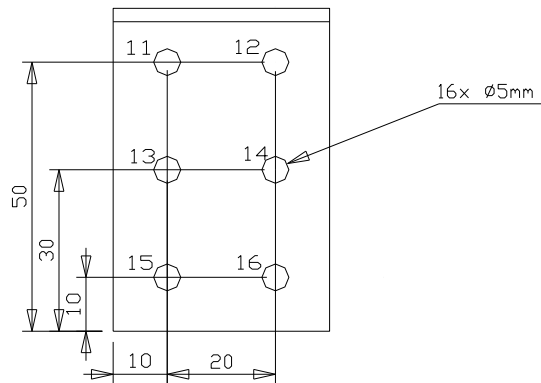
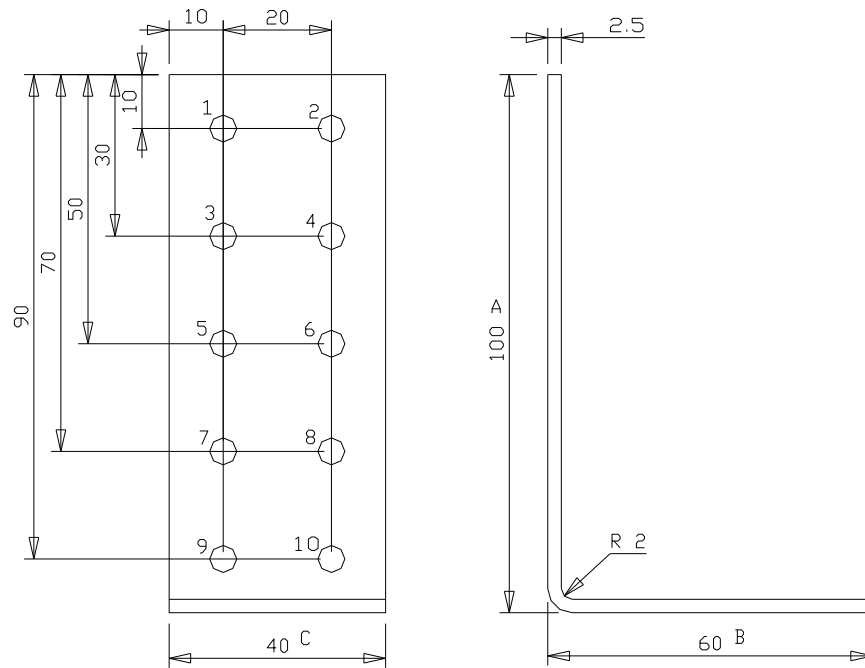

August Vormann
GmbH&Co.KG
Heilenbeckerstr.
58256 Ennepetal

Lochplattenwinkel
70914040

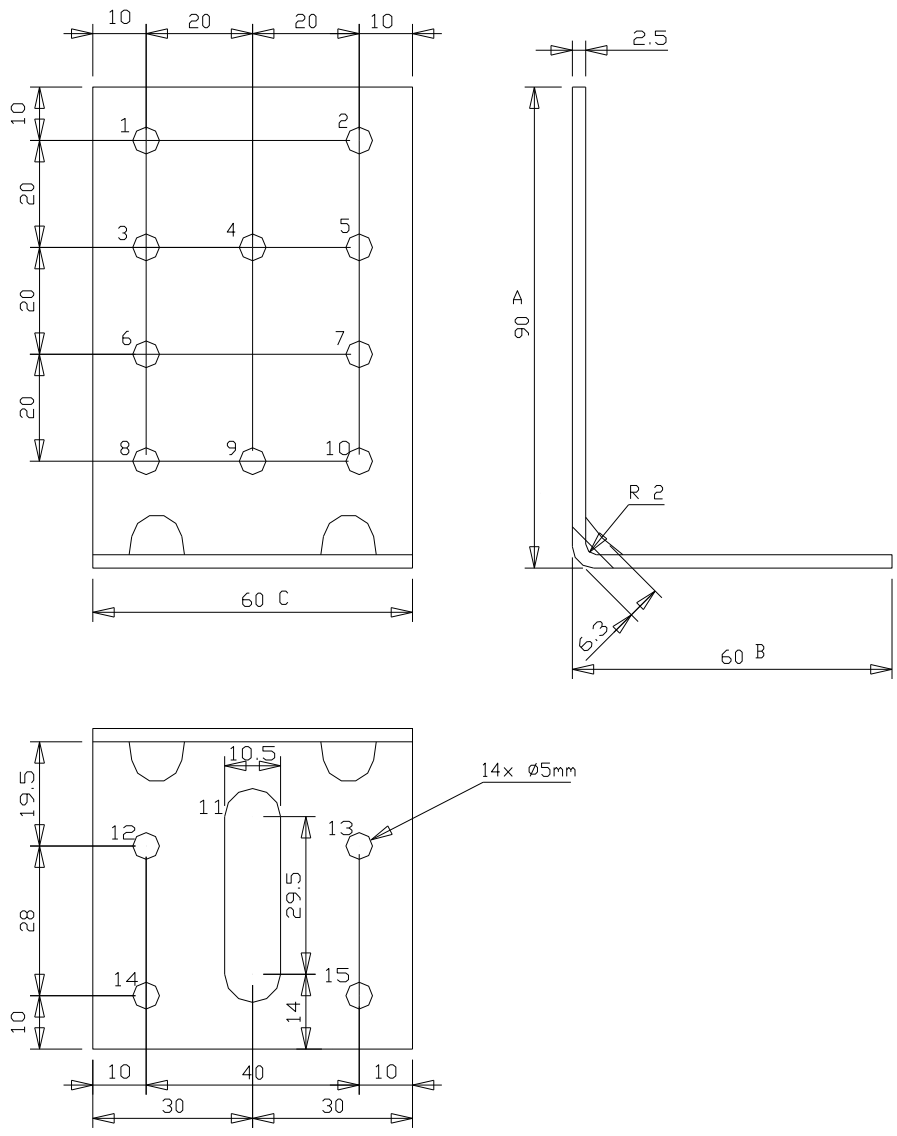

August Vormann
 GmbH&Co.KG
 Heilenbeckerstr.
 58256 Ennepetal

Winkelverbinder
 70915

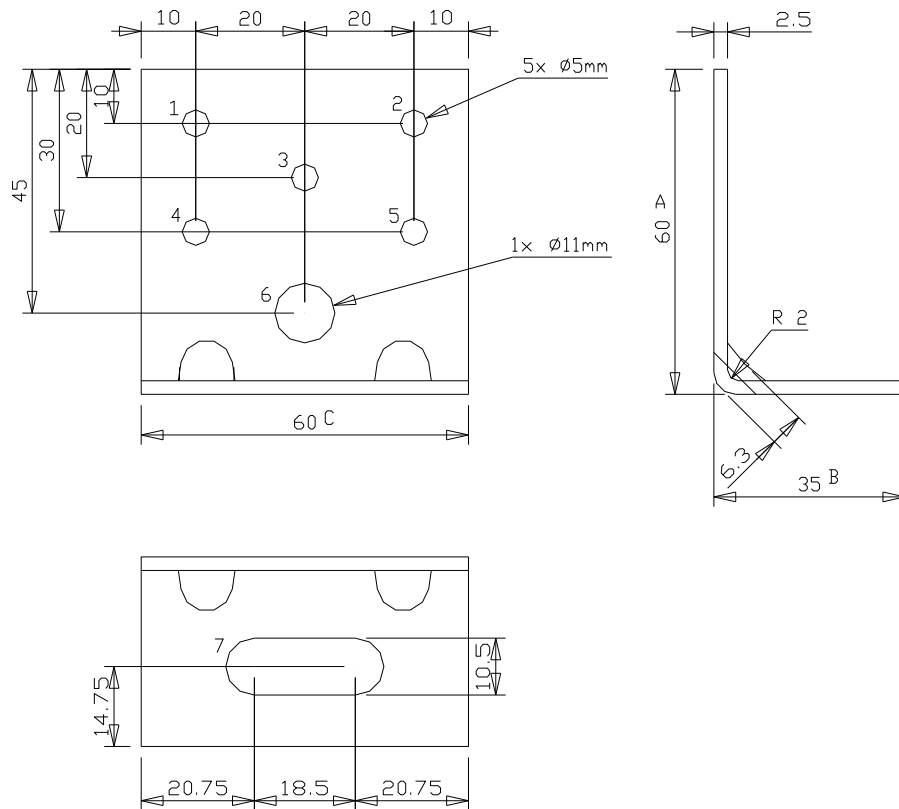

August Vormann
GmbH&Co.KG
Heilenbeckerstr.
58256 Ennepetal

Winkelverbinder
70916

Speicher Code: /z/hv1/70916so

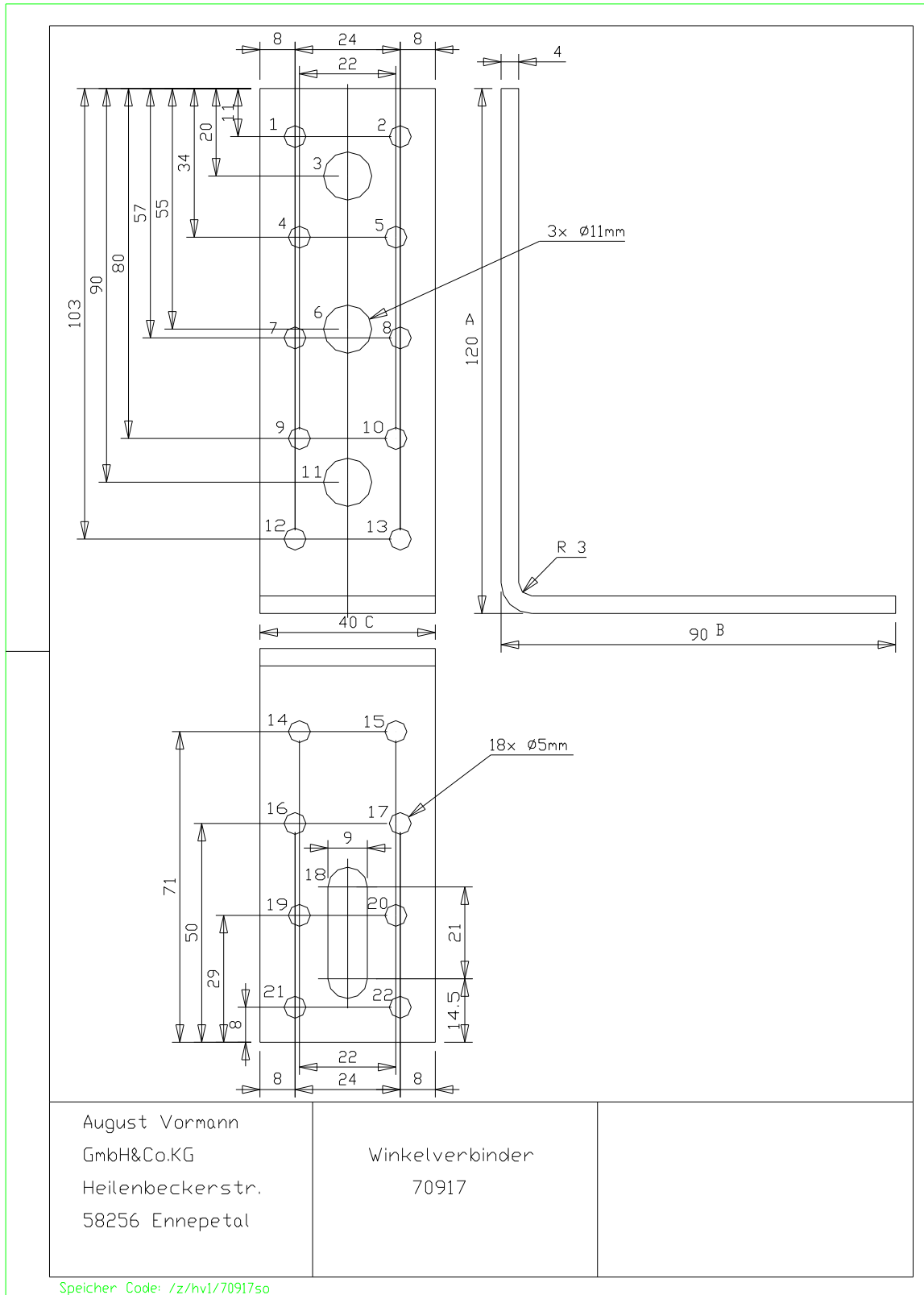

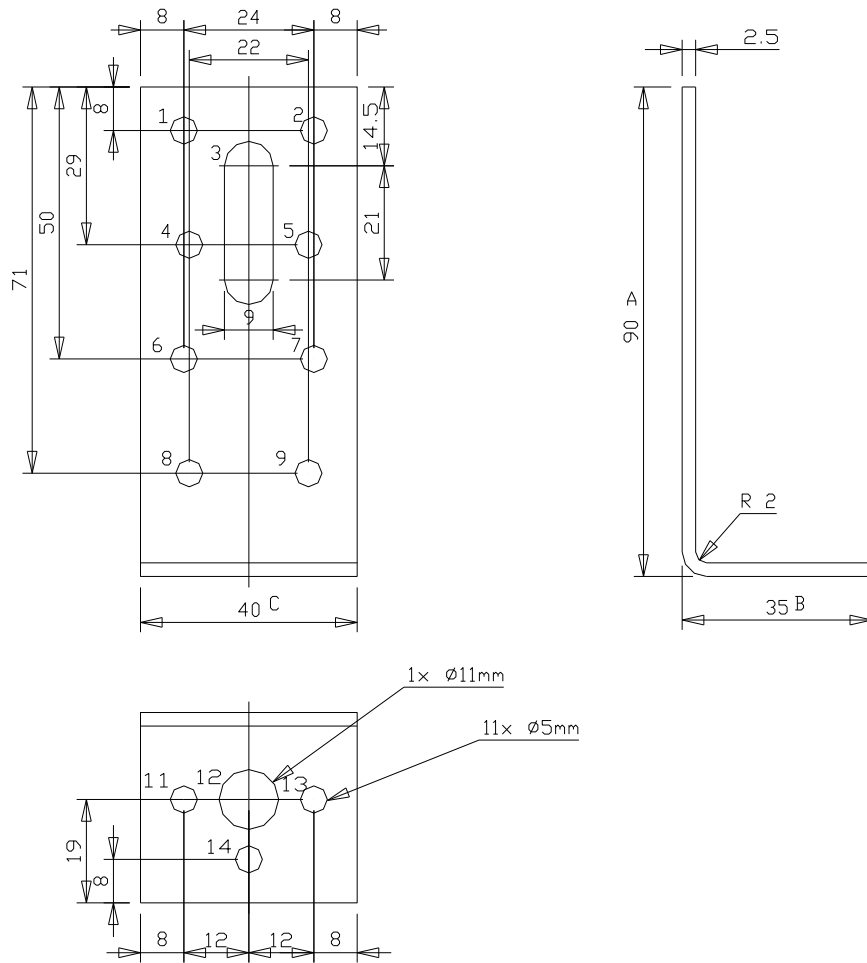

August Vormann
GmbH&Co.KG
Heilenbeckerstr.
58256 Ennepetal

Winkelverbinder
70918

Speicher Code: /z/hvl/70918so

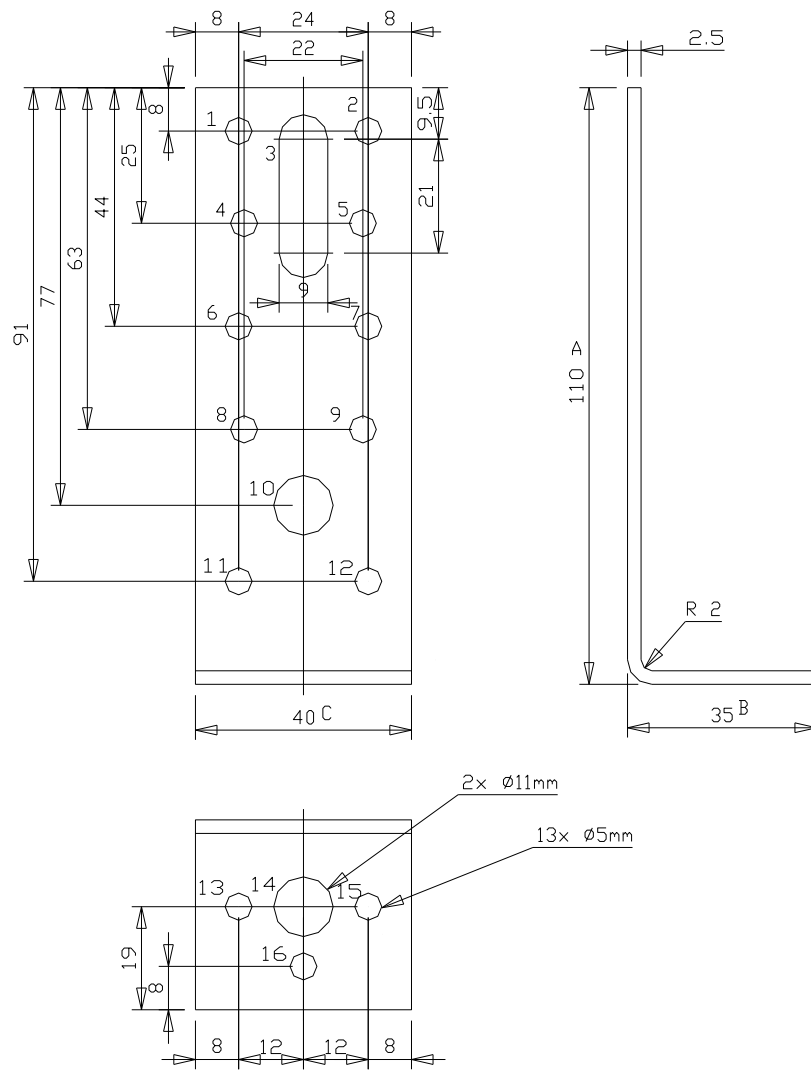

August Vormann
 GmbH&Co.KG
 Heilenbeckerstr.
 58256 Ennepetal

Winkelverbinder
 70919

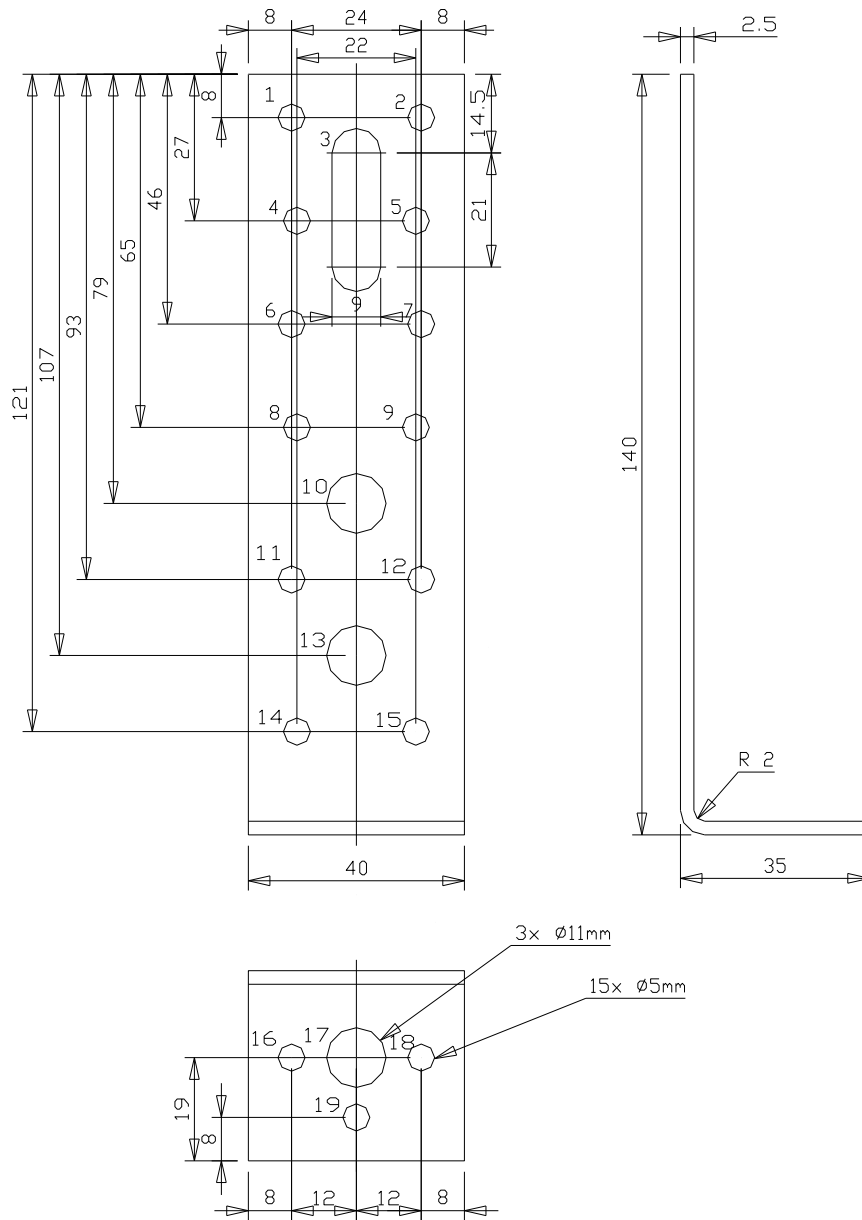

August Vormann
GmbH&Co.KG
Heilenbeckerstr.
58256 Ennepetal

Winkelverbinder
70920

Speicher Code: /z/hv1/70920so

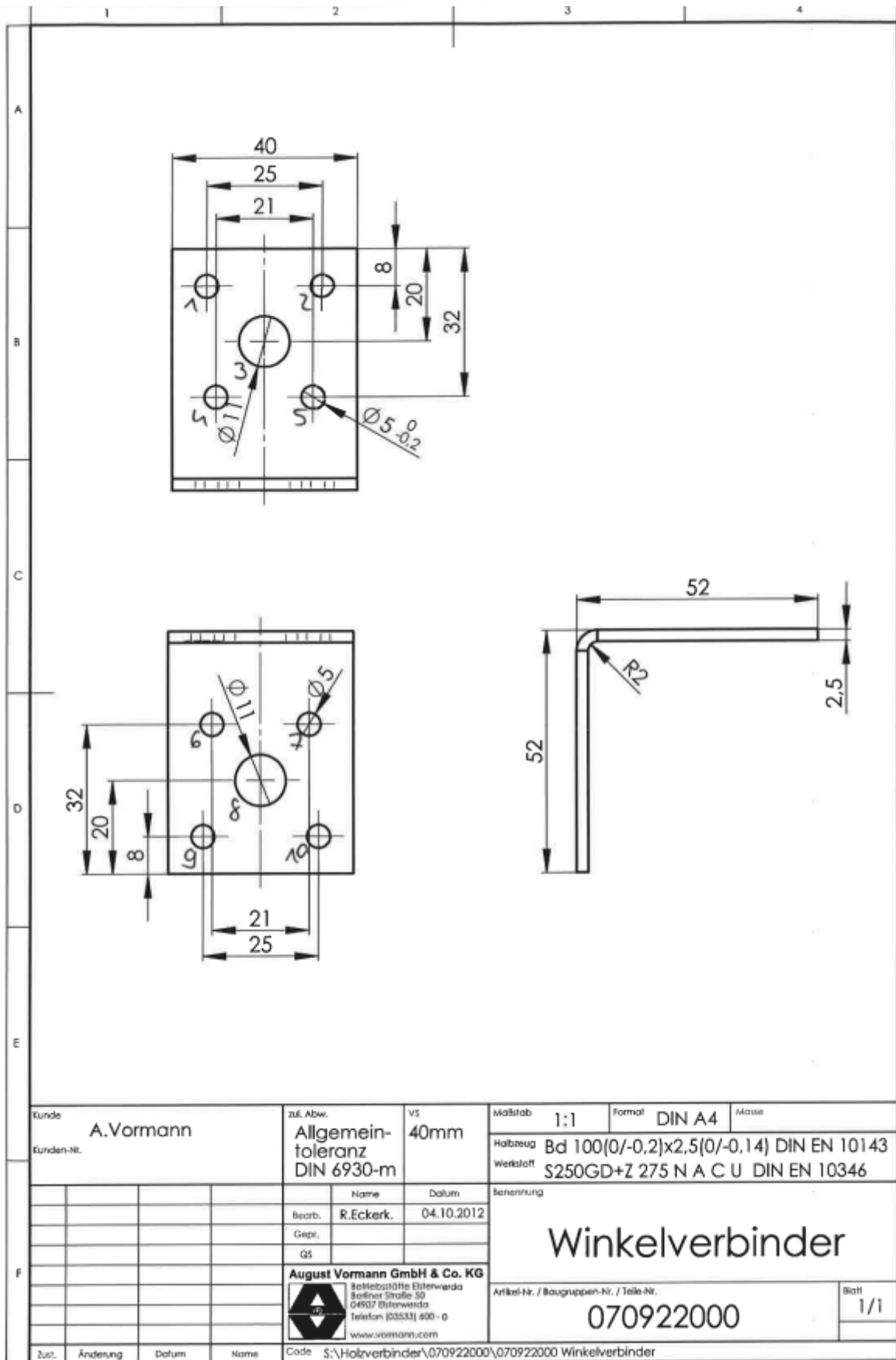

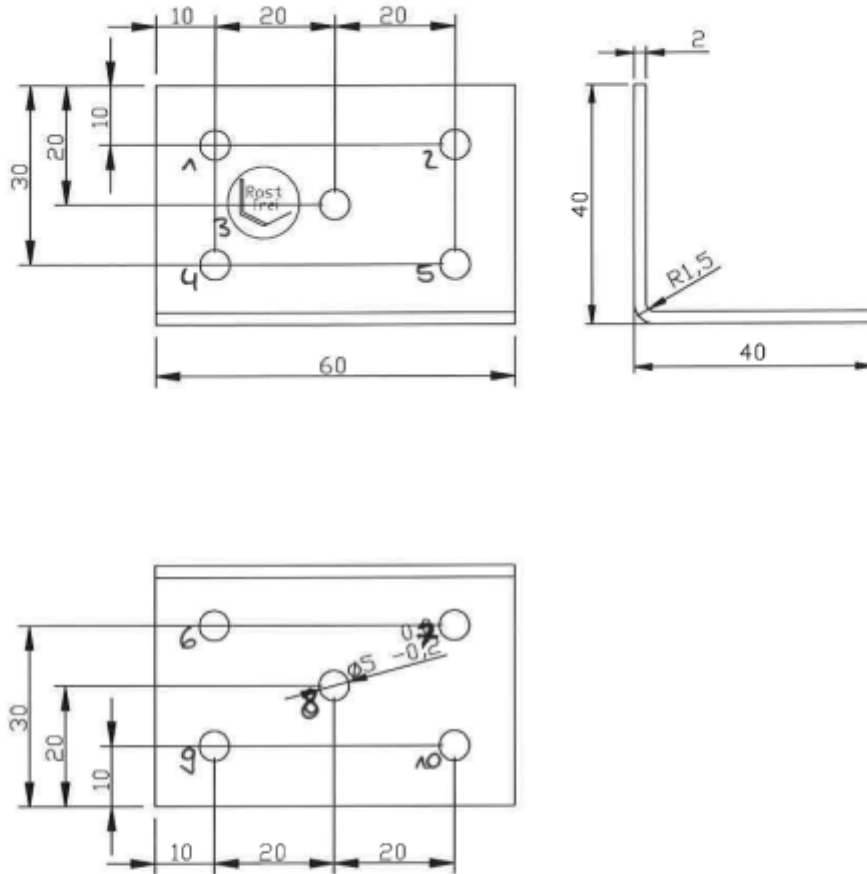

Oberfläche trowalisiert

Kunde: August Vormann GmbH & Co. 58256 Ennepetal		Material: 1.4301		Maßstab 1:1	Format A 4
Kundennr.: xx		B x S : 76x2,0 VS : 60		Code: /z/hv1/70934rf-1	
A r t i k e l					
				X	
				Lochplattenwinkel	
				X	
				Art.Nr.: 70934 RF	
				Blatt x	
Zust.	Änderung	Datum	Name		

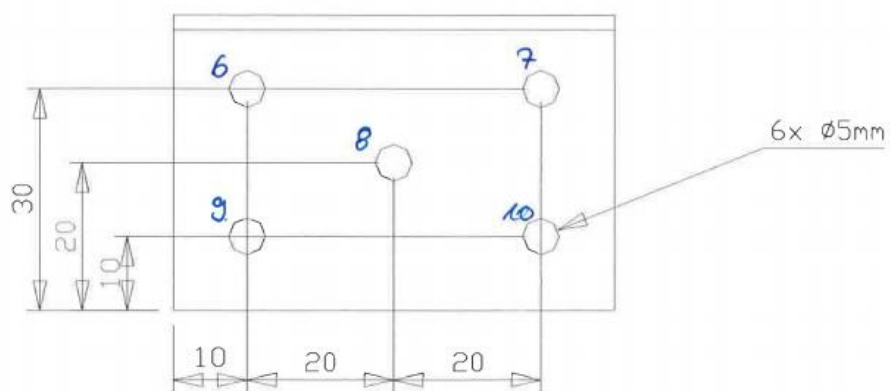
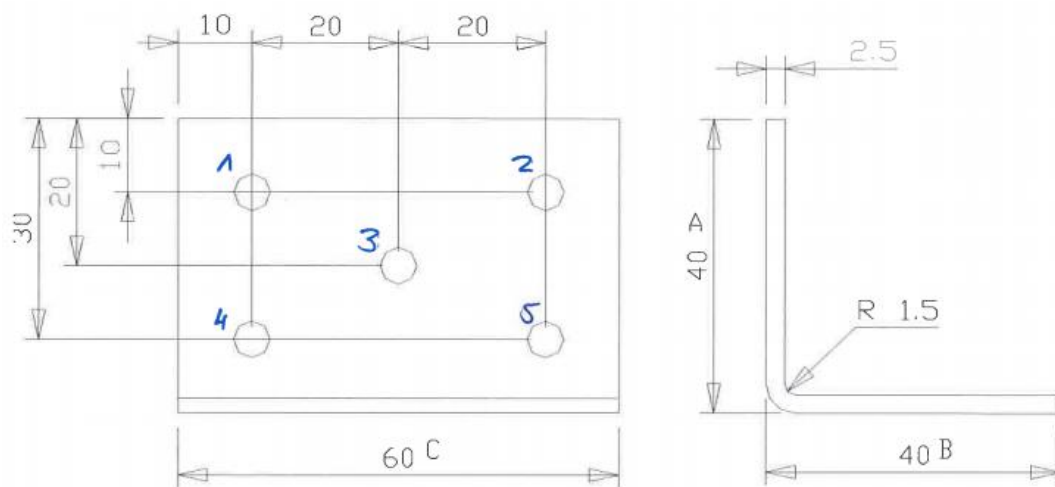

070 934 000 with 40 x 40 x 60 x 2,5 mm

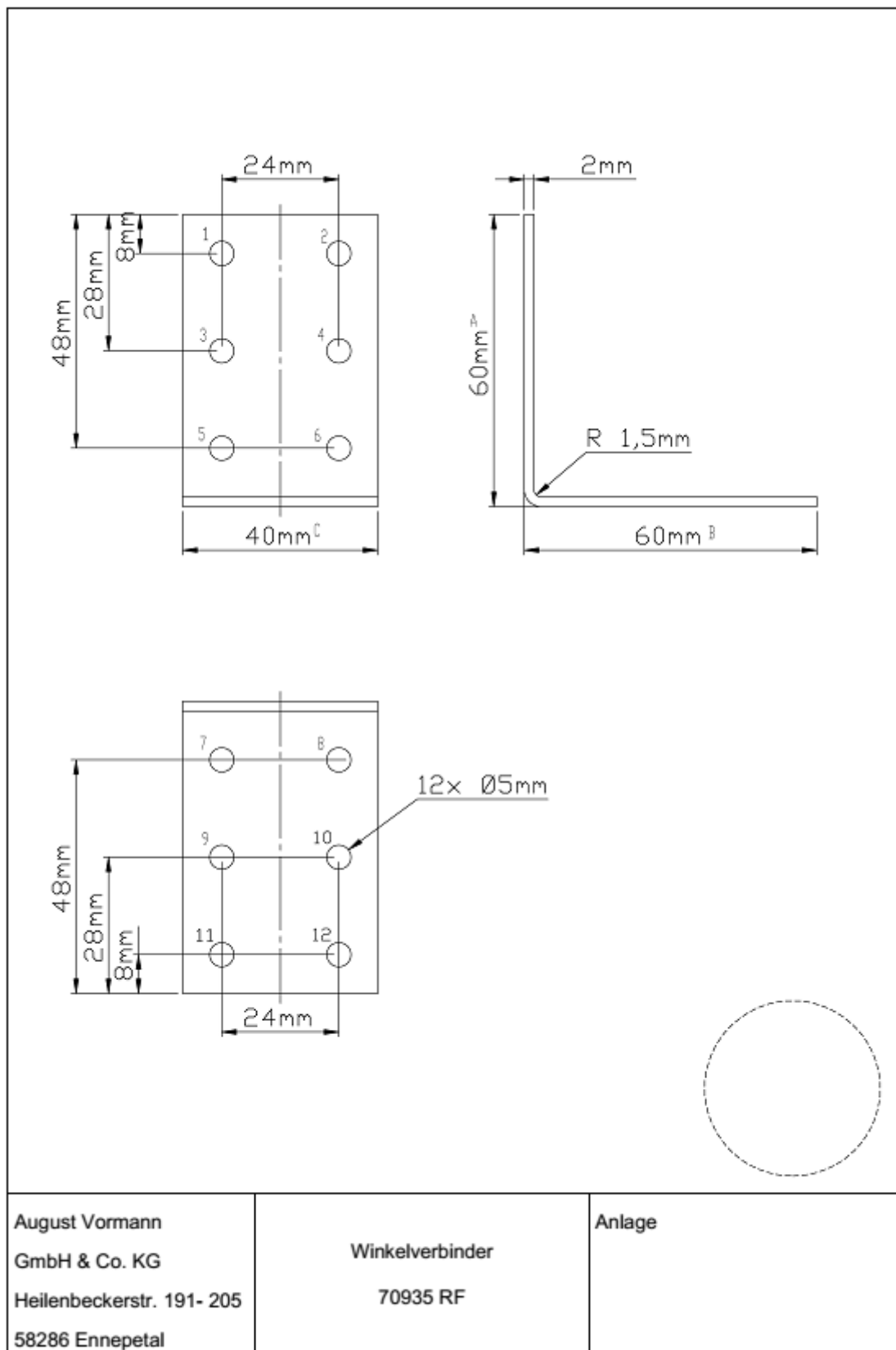

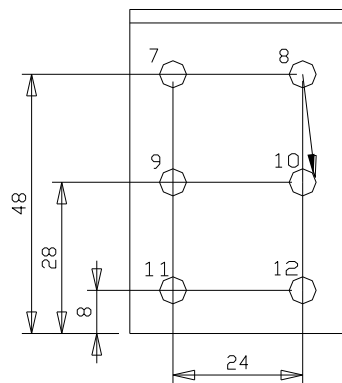
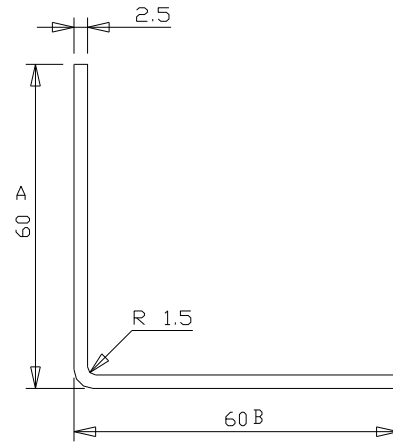
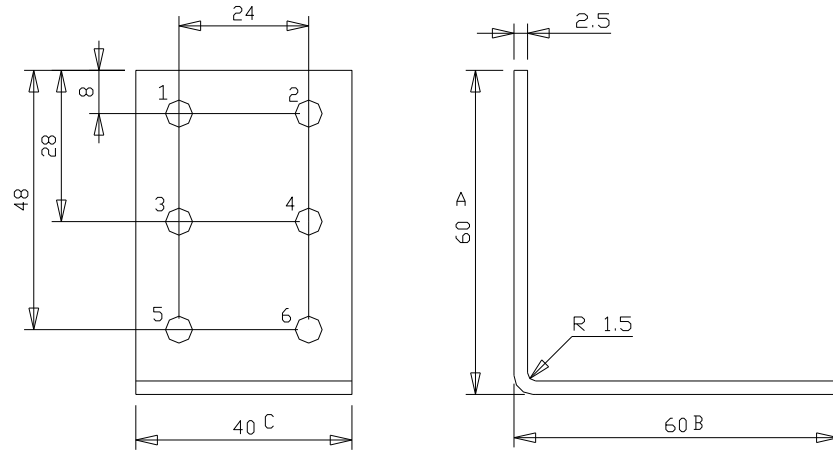

R19.2186x \varnothing 5mm

August Vormann
GmbH&Co.KG
Heilenbeckerstr.
58256 Ennepetal

Lochplattenwinkel
70935

Speicher Code: /z/hv1/70935so

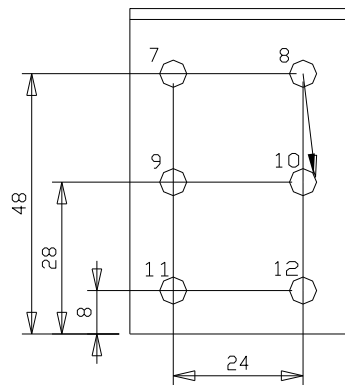
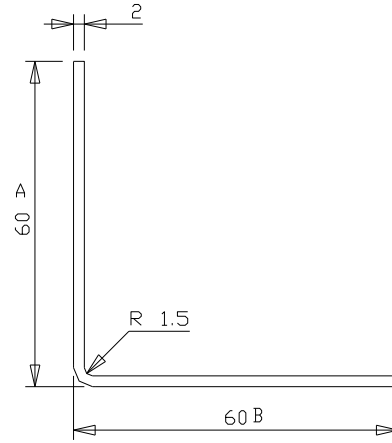
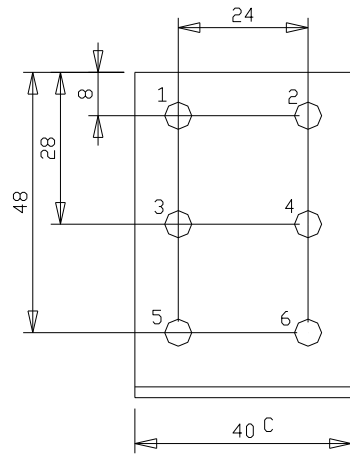

R19.2186x Ø5mm

August Vormann
GmbH&Co.KG
Heilenbeckerstr.
58256 Ennepetal

Lochplattenwinkel
70935020

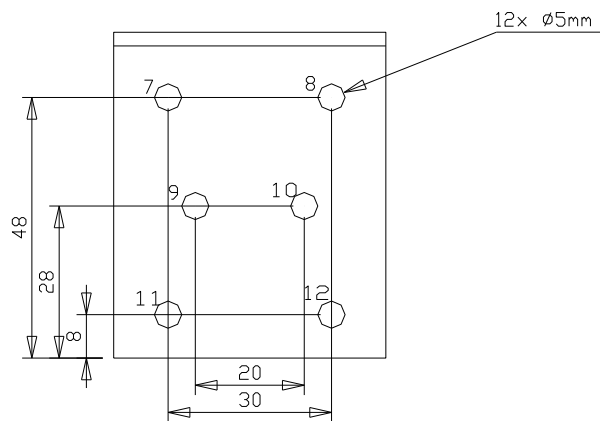
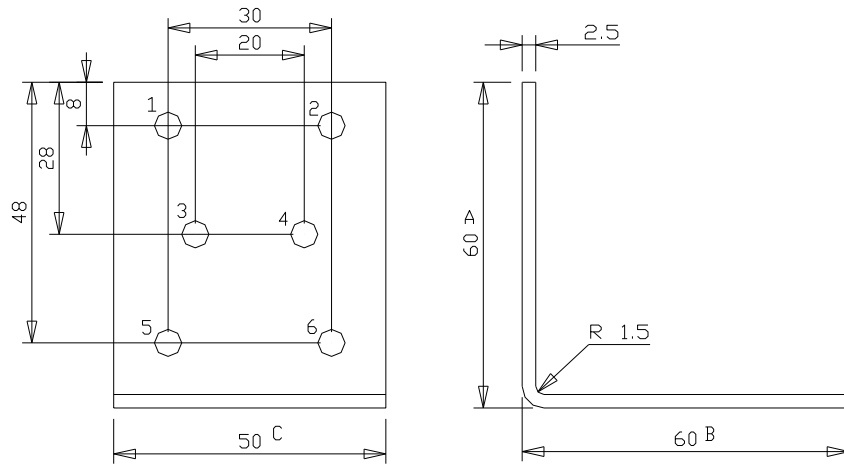

August Vormann
GmbH&Co.KG
Heilenbeckerstr.
58256 Ennepetal

Lochplattenwinkel
70936

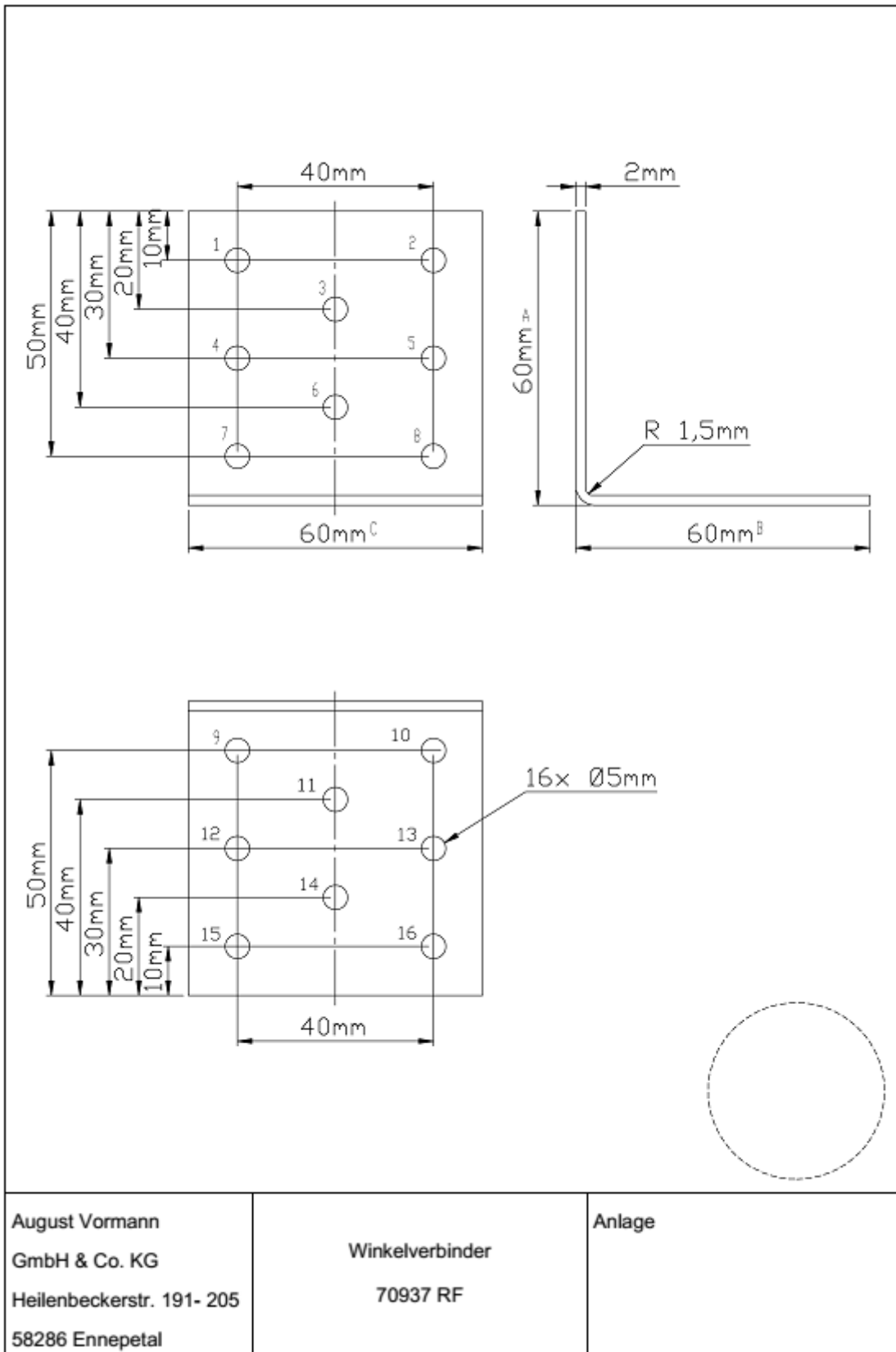

<p>August Vormann GmbH & Co. KG Heilenbeckerstr. 191- 205 58286 Ennepetal</p>	<p>Winkelverbinder 70937 RF</p>	<p>Anlage</p>
--	--	---------------

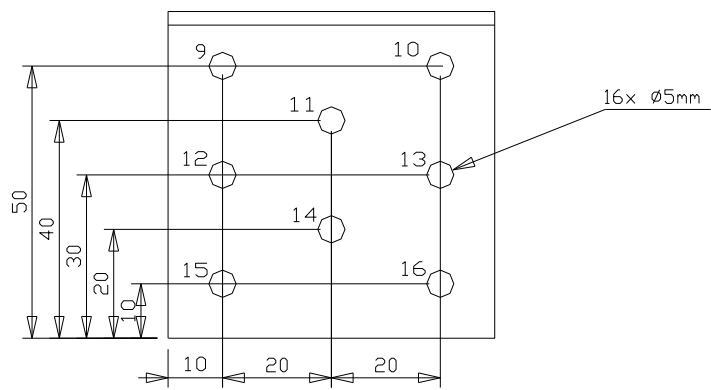
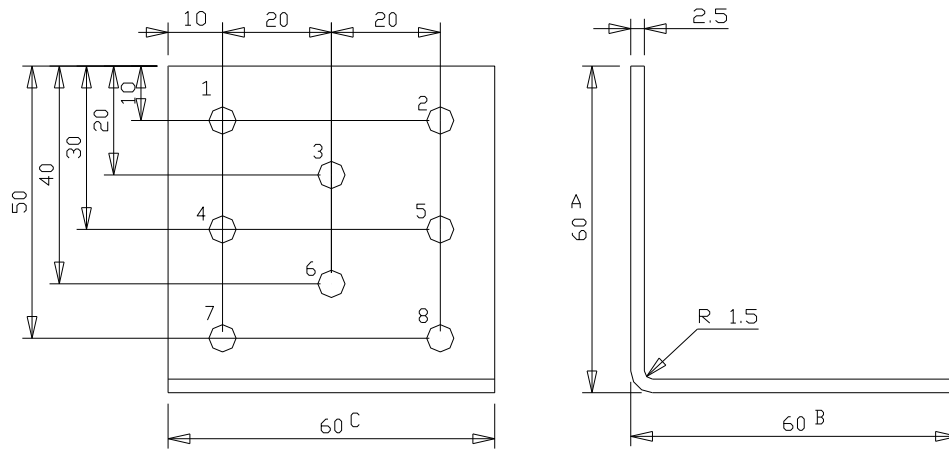

August Vormann
GmbH&Co.KG
Heilenbeckerstr.
58256 Ennepetal

Lochplattenwinkel
70937

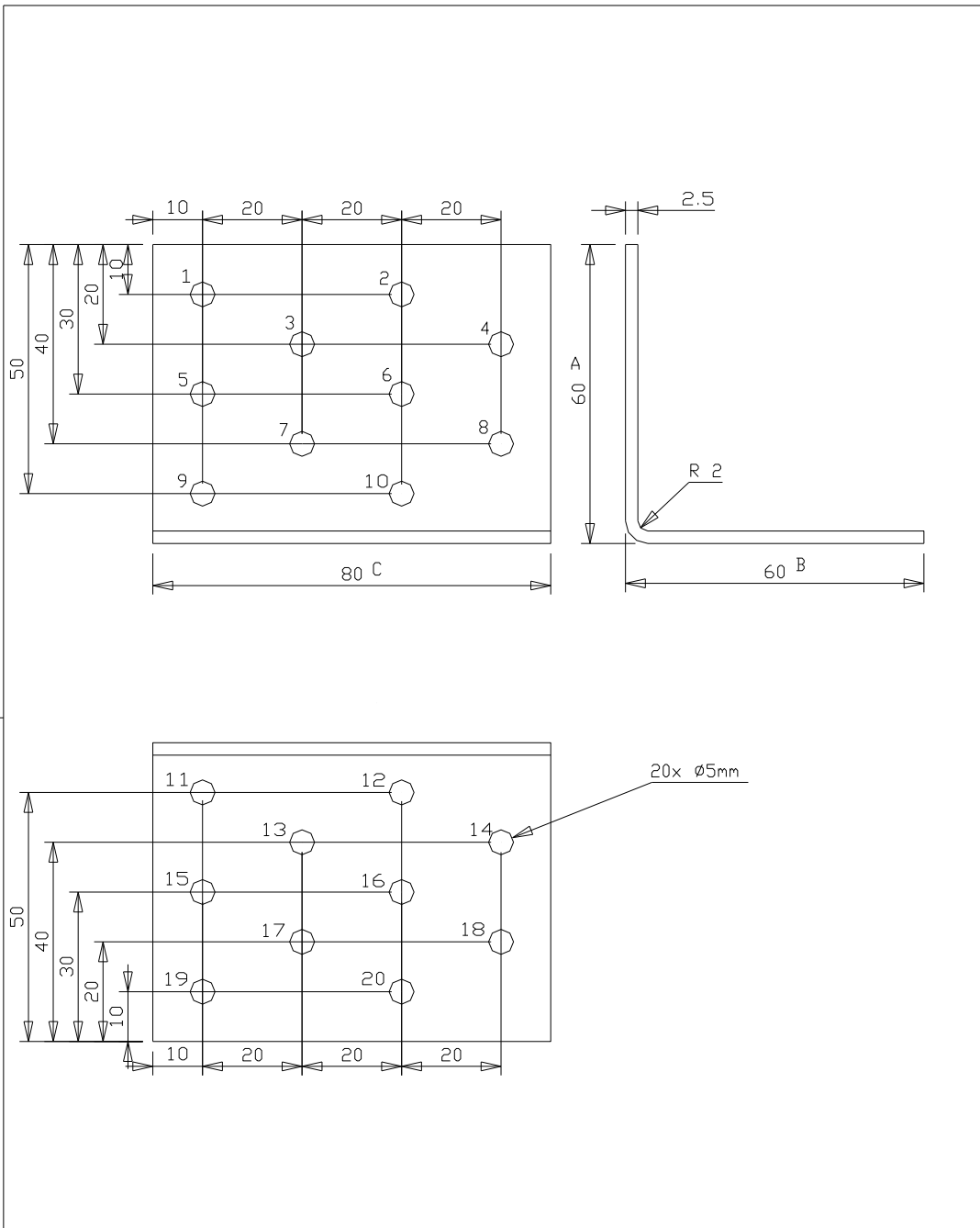

<p>August Vormann GmbH&Co.KG Heilenbeckerstr. 58256 Ennepetal</p>	<p>Lochplattenwinkel 70938</p>	
---	------------------------------------	--

Speicher Code: /z/hv1/70938so

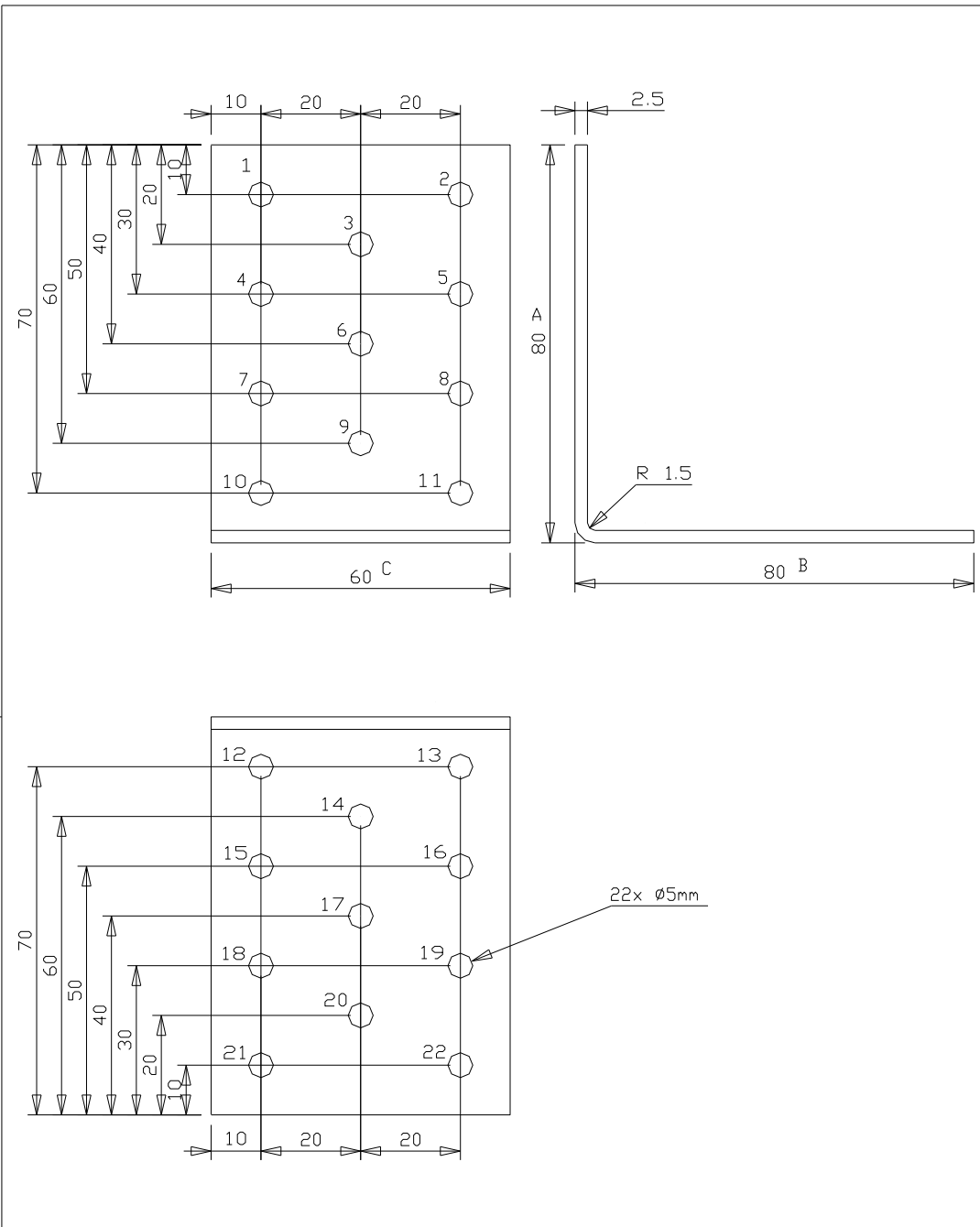

<p>August Vormann GmbH&Co.KG Heilenbeckerstr. 58256 Ennepetal</p>	<p>Lochplattenwinkel 70940</p>	
---	------------------------------------	--

Speicher Code: /z/hv1/70940so

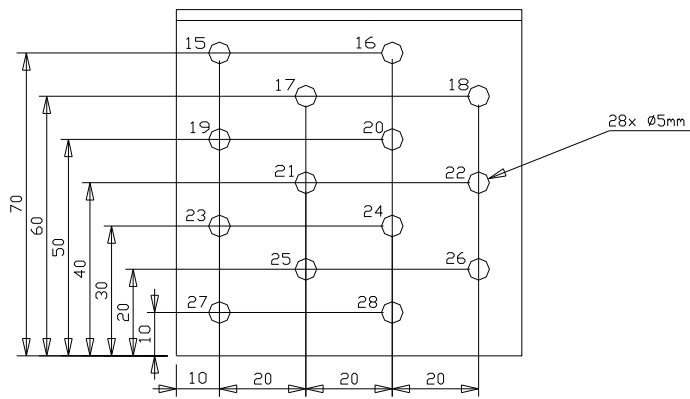
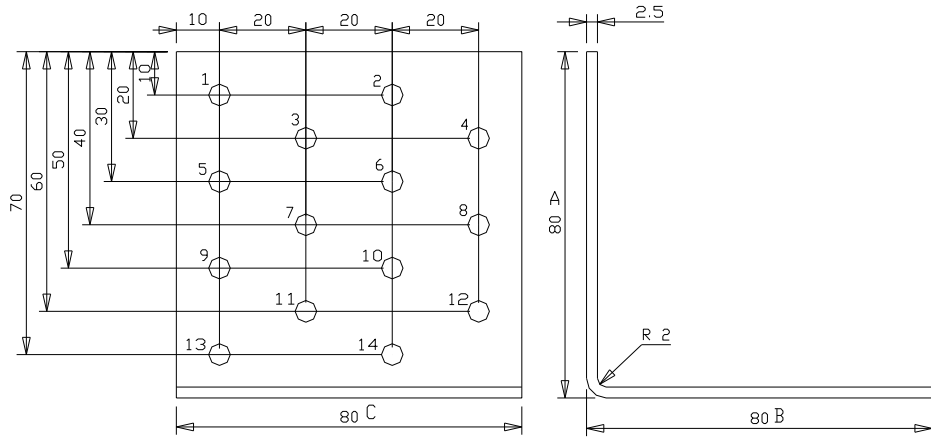

August Vormann
GmbH&Co.KG
Heilenbeckerstr.
58256 Ennepetal

Lochplattenwinkel
70941

Speicher Code: /z/hv1/70941so

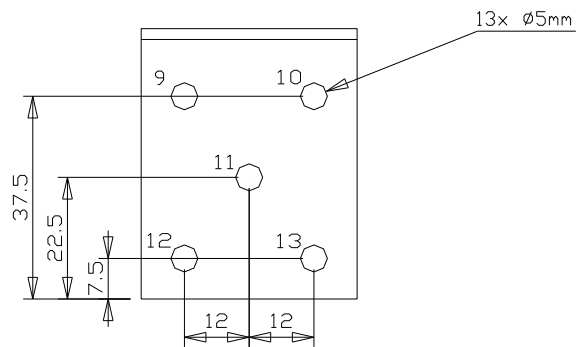
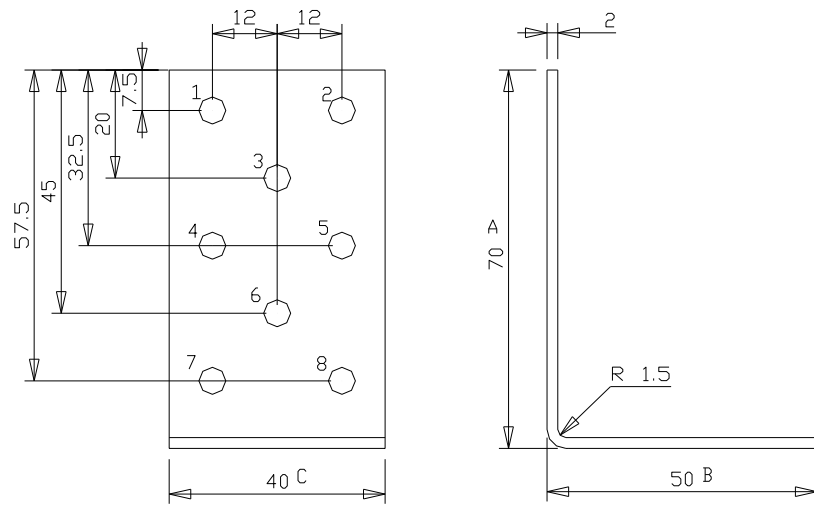

August Vormann
GmbH&Co.KG
Heilenbeckerstr.
58256 Ennepetal

Lochplattenwinkel
70942

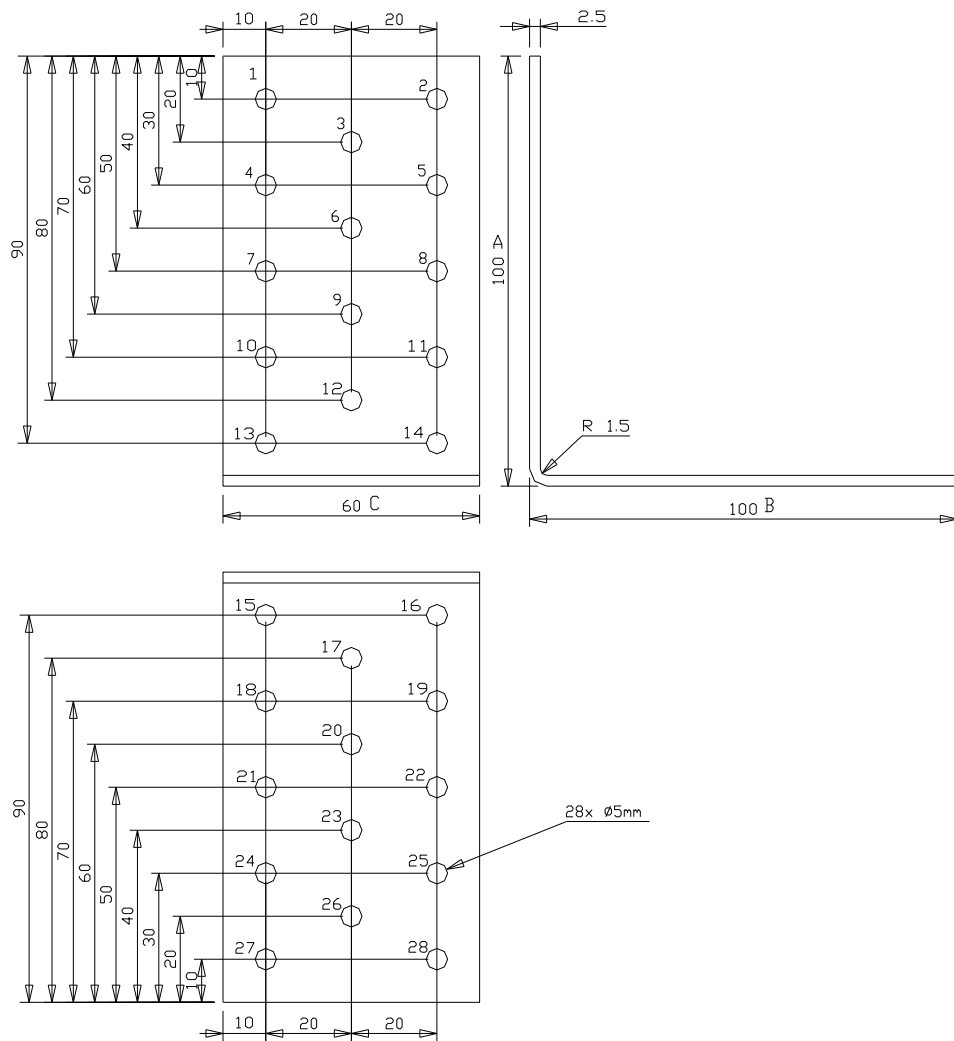

August Vormann
GmbH&Co.KG
Heilenbeckerstr.
58256 Ennepetal

Lochplattenwinkel
70943

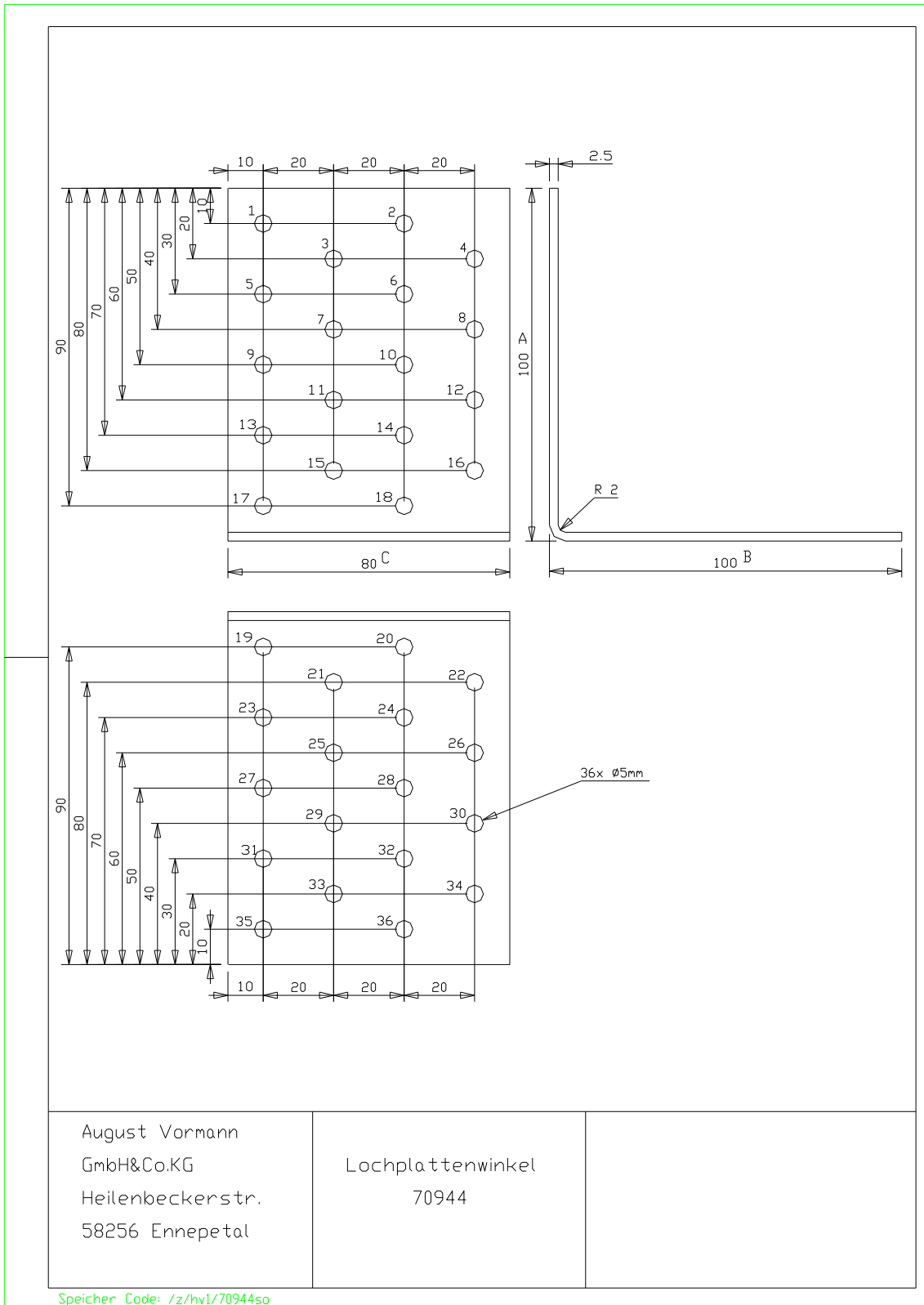

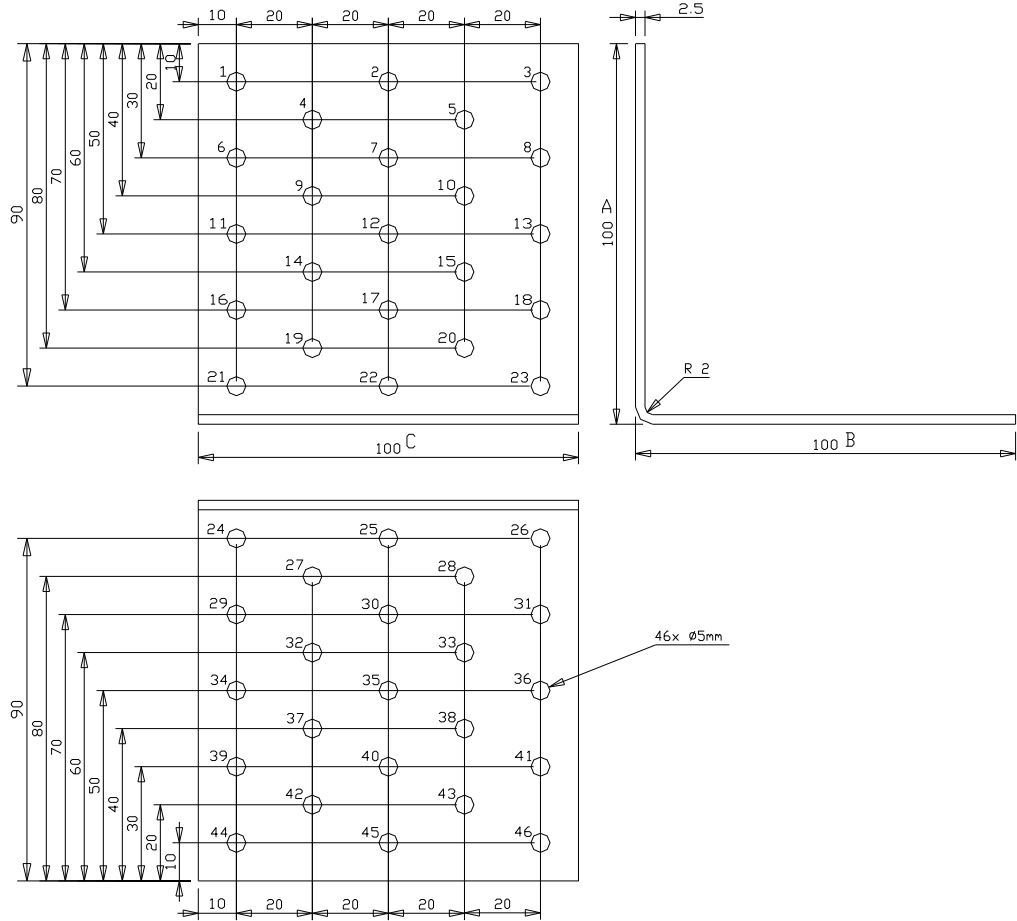

<p>August Vormann GmbH&Co.KG Heilenbeckerstr. 58256 Ennepetal</p>	<p>Lochplattenwinkel 70945</p>	
---	------------------------------------	--

Speicher Code: /z/hvl/70945so

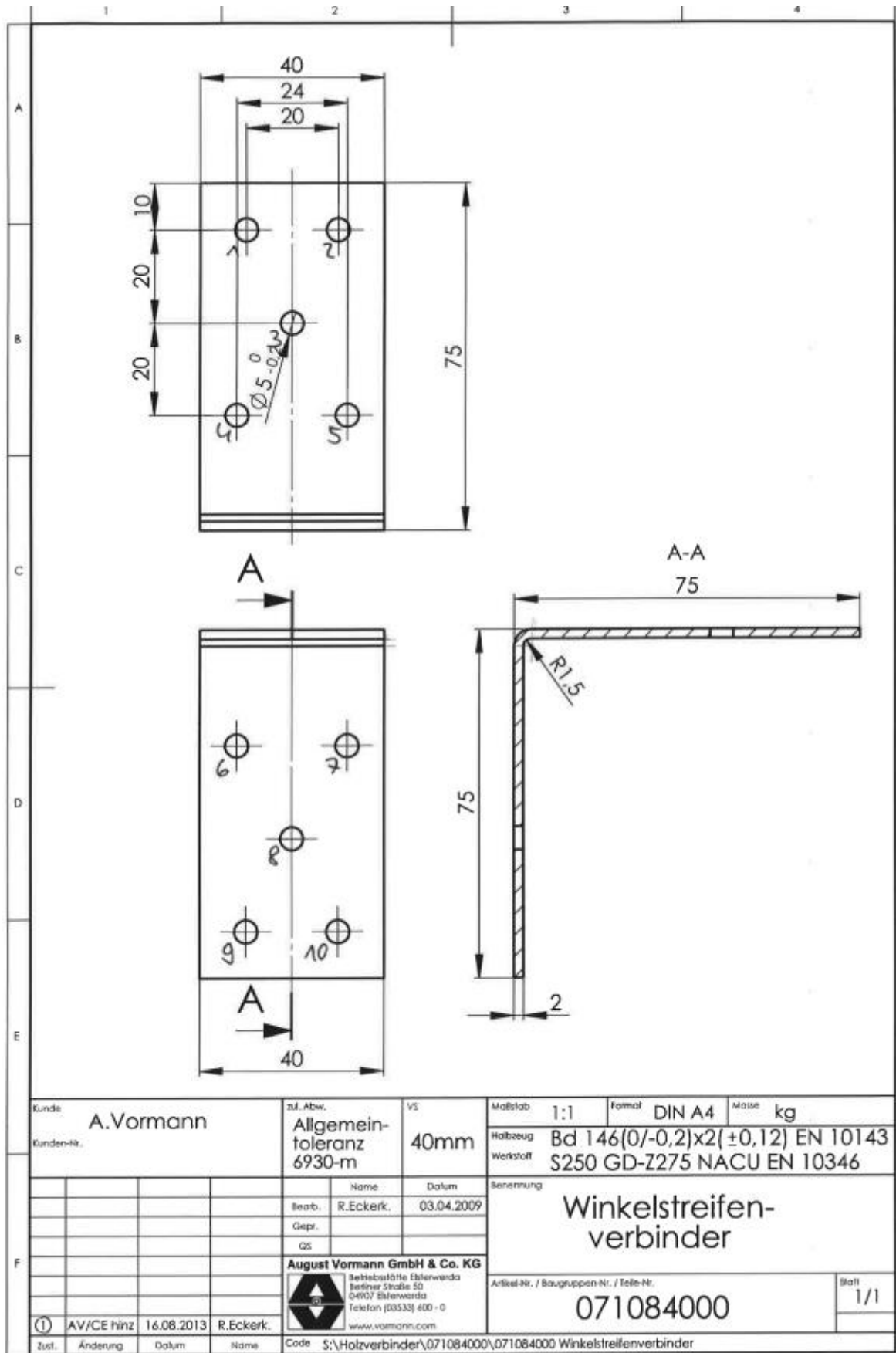

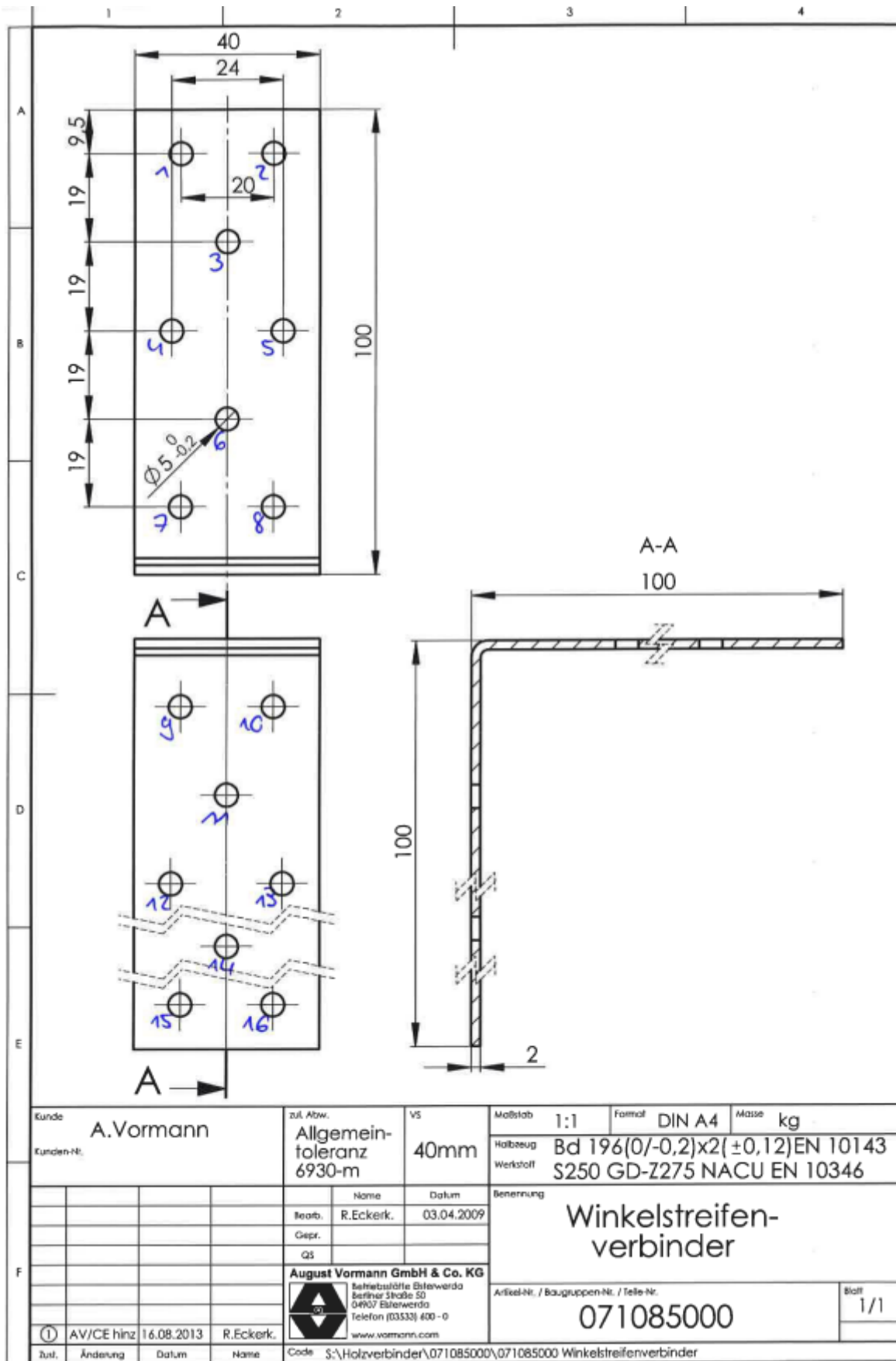

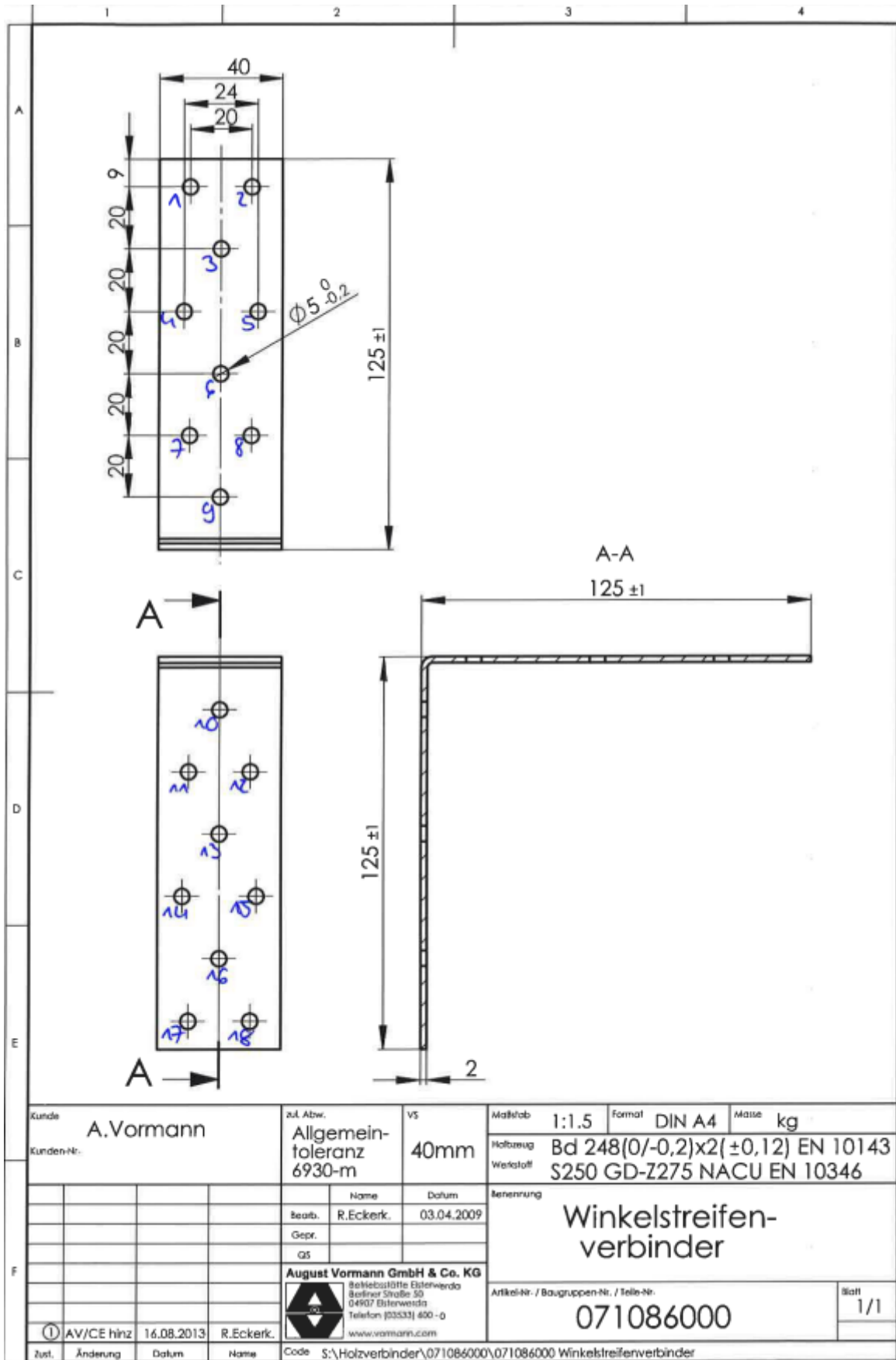

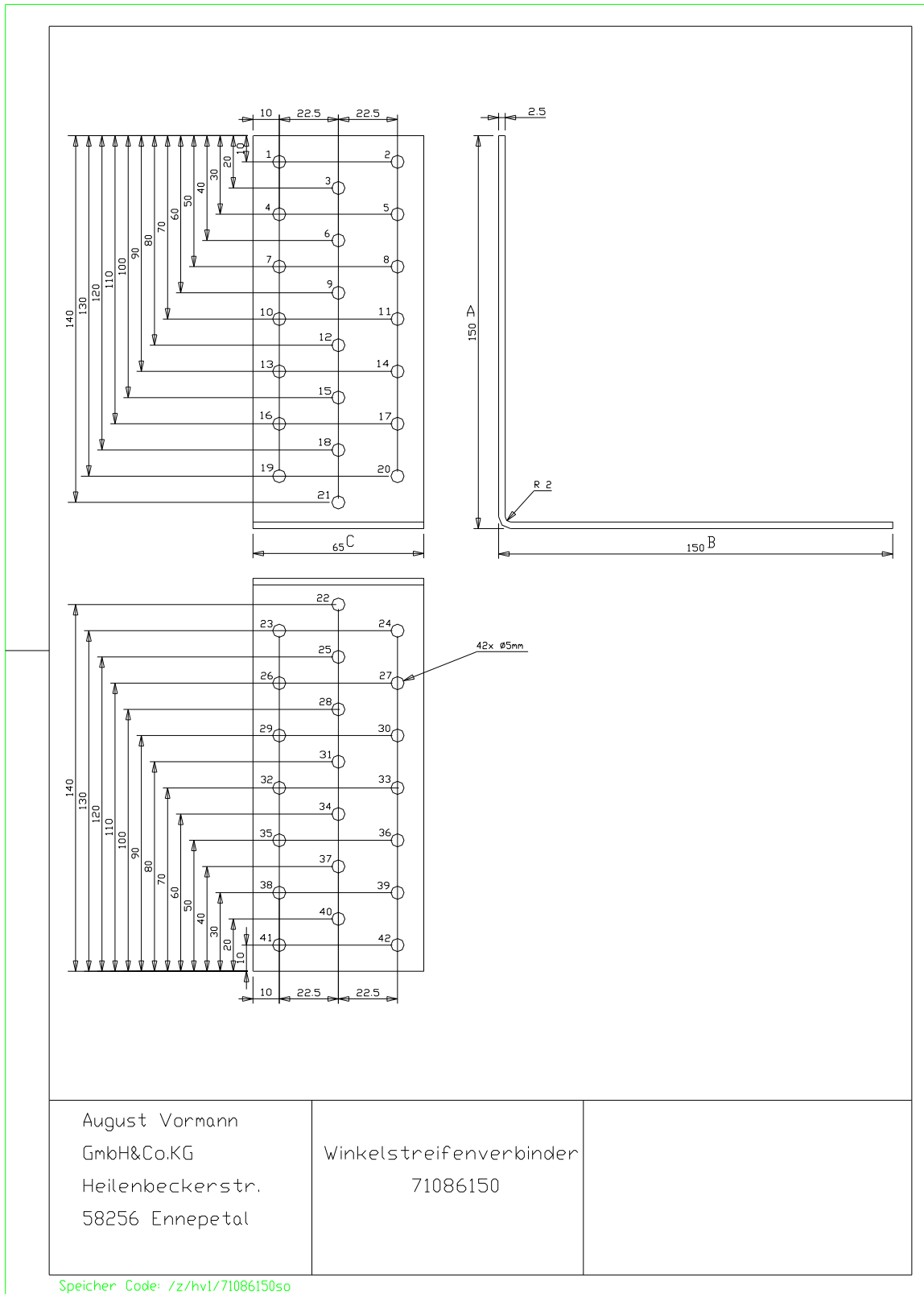

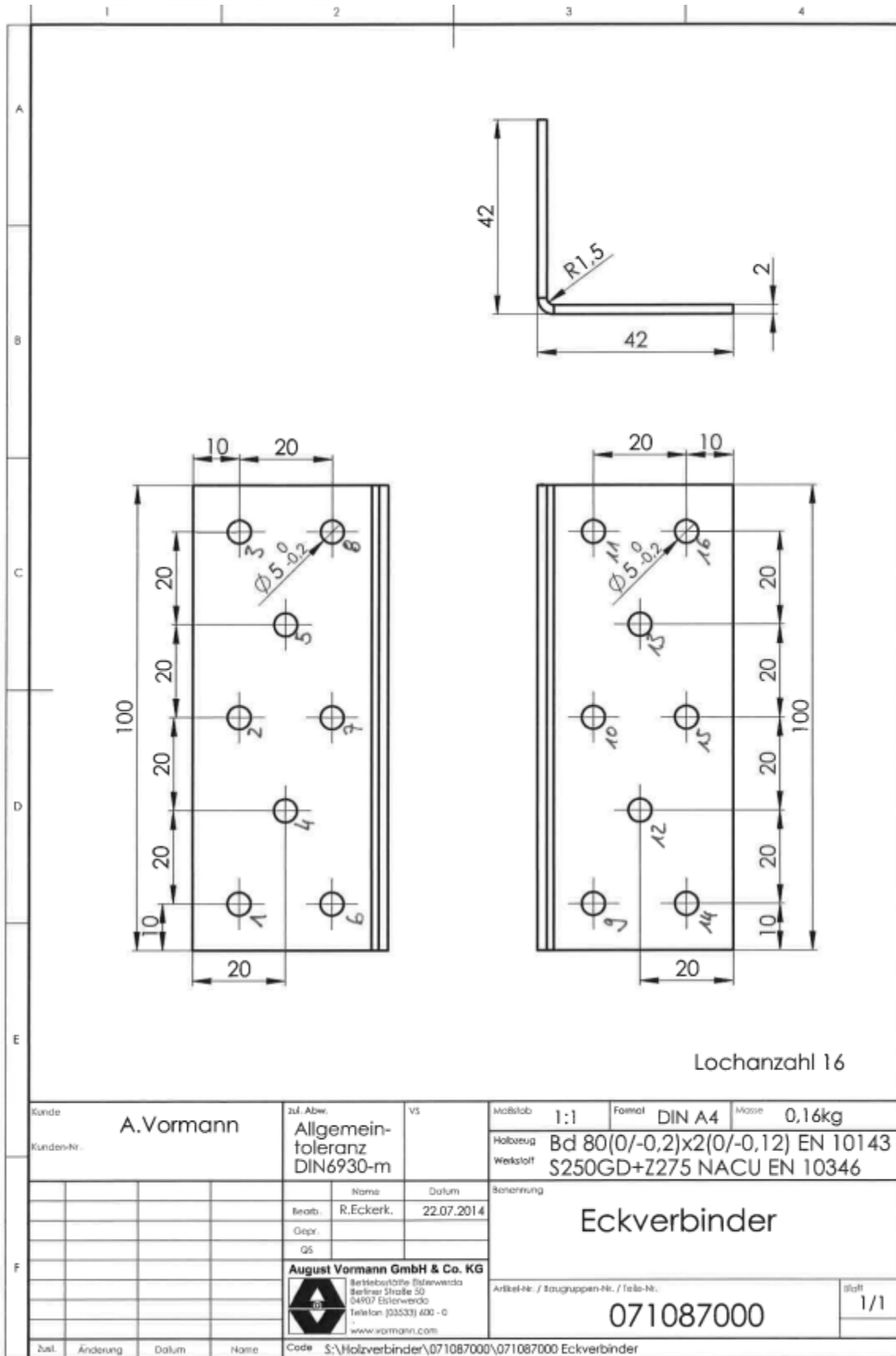

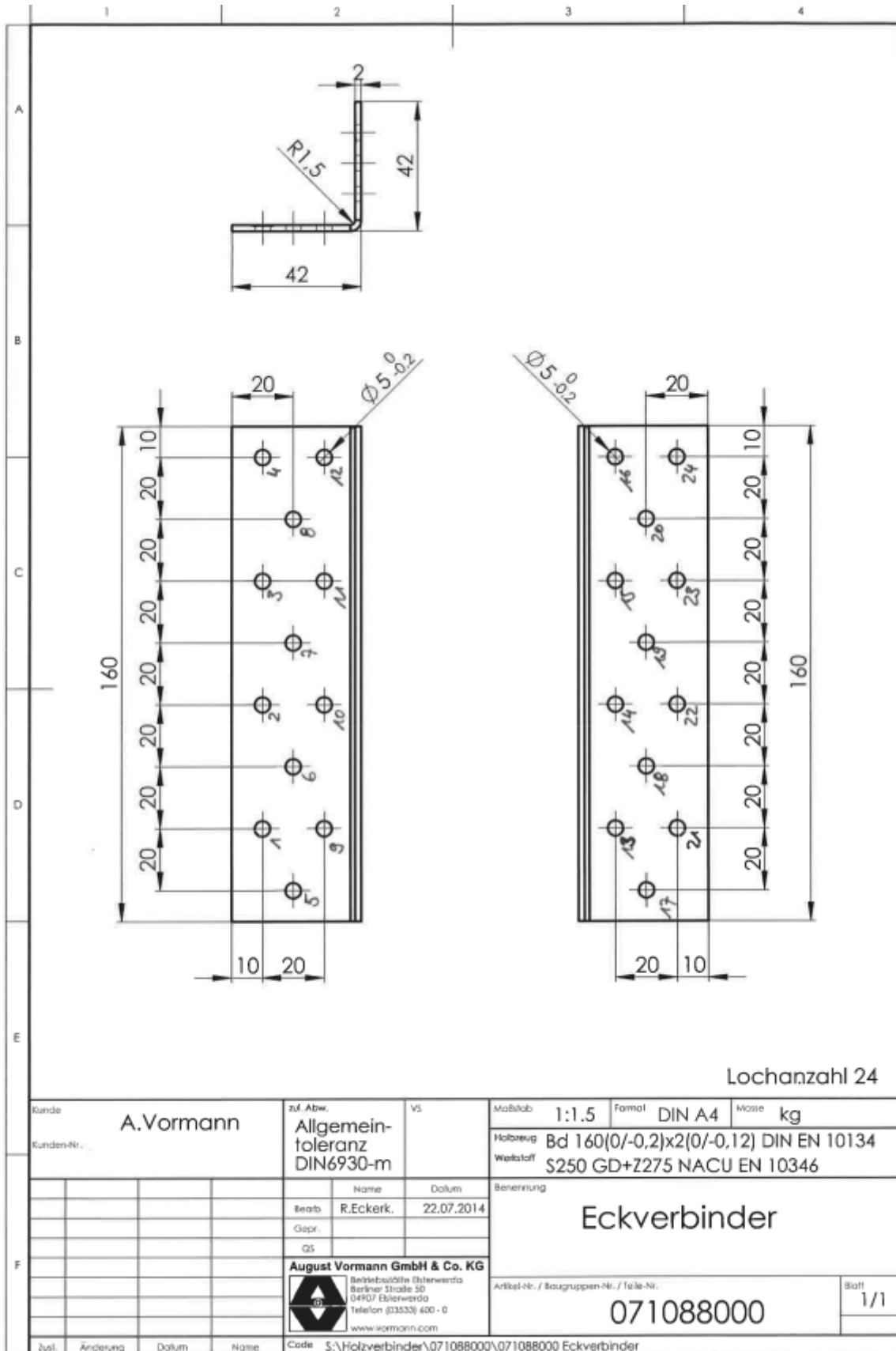

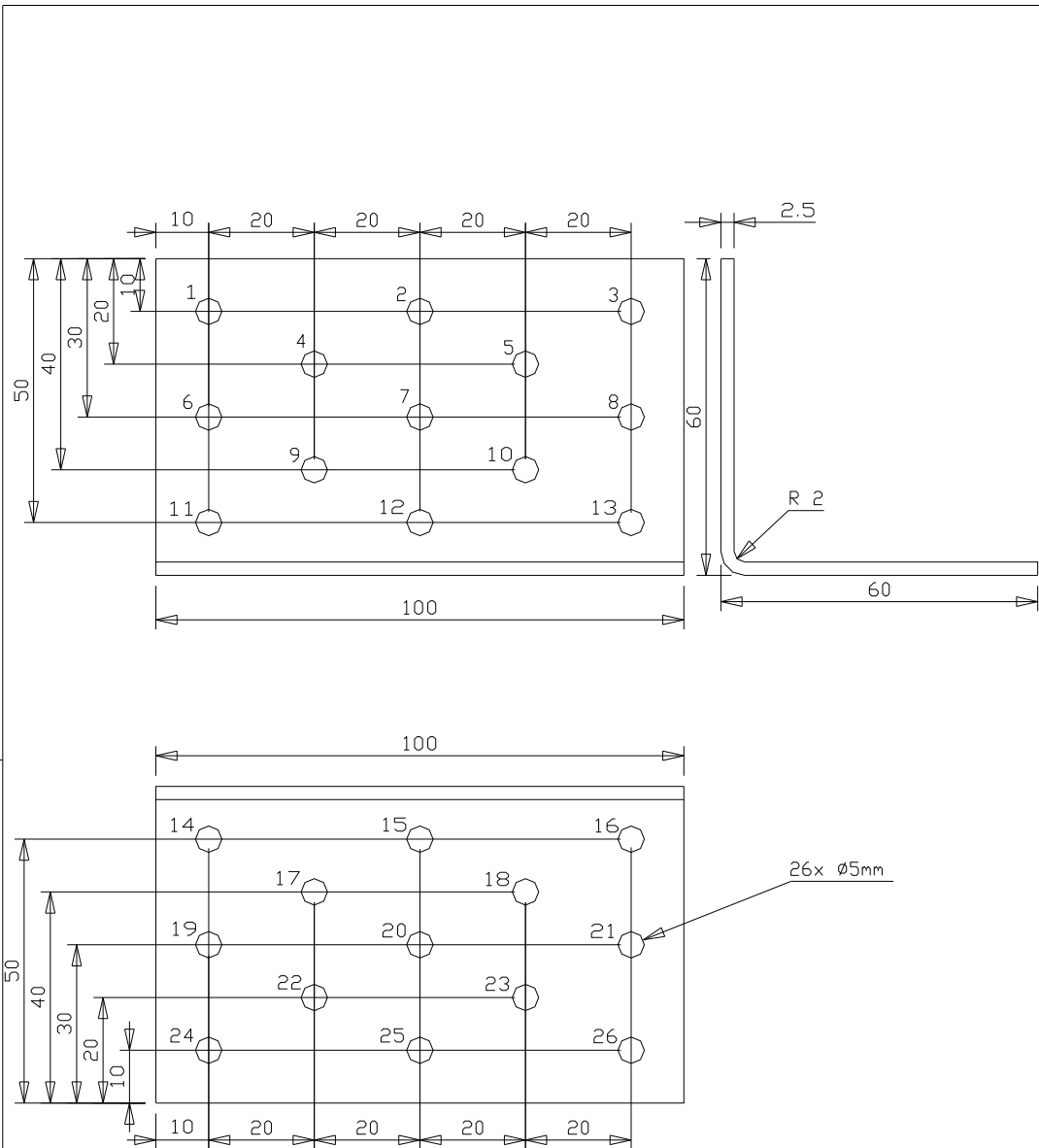

August Vormann
GmbH&Co.KG
Heilenbeckerstr.
58256 Ennepetal

Eckverbinder
71089

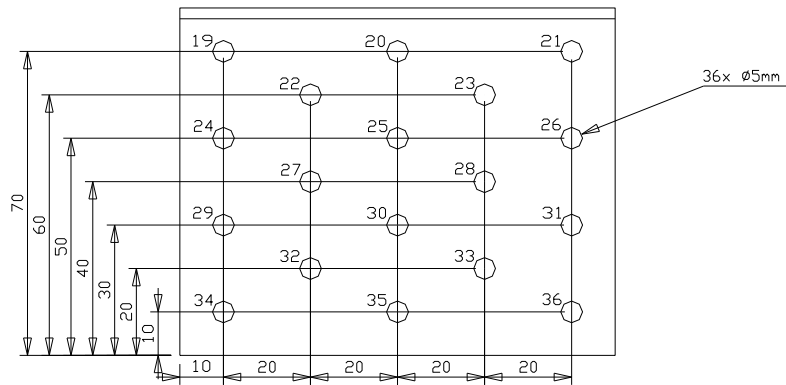
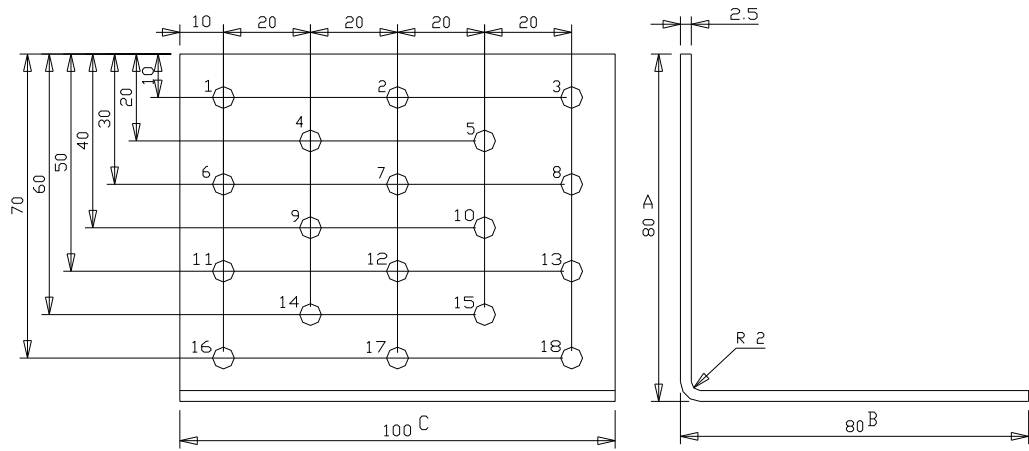

August Vormann
GmbH&Co.KG
Heilenbeckerstr.
58256 Ennepetal

Eckverbinder
71090

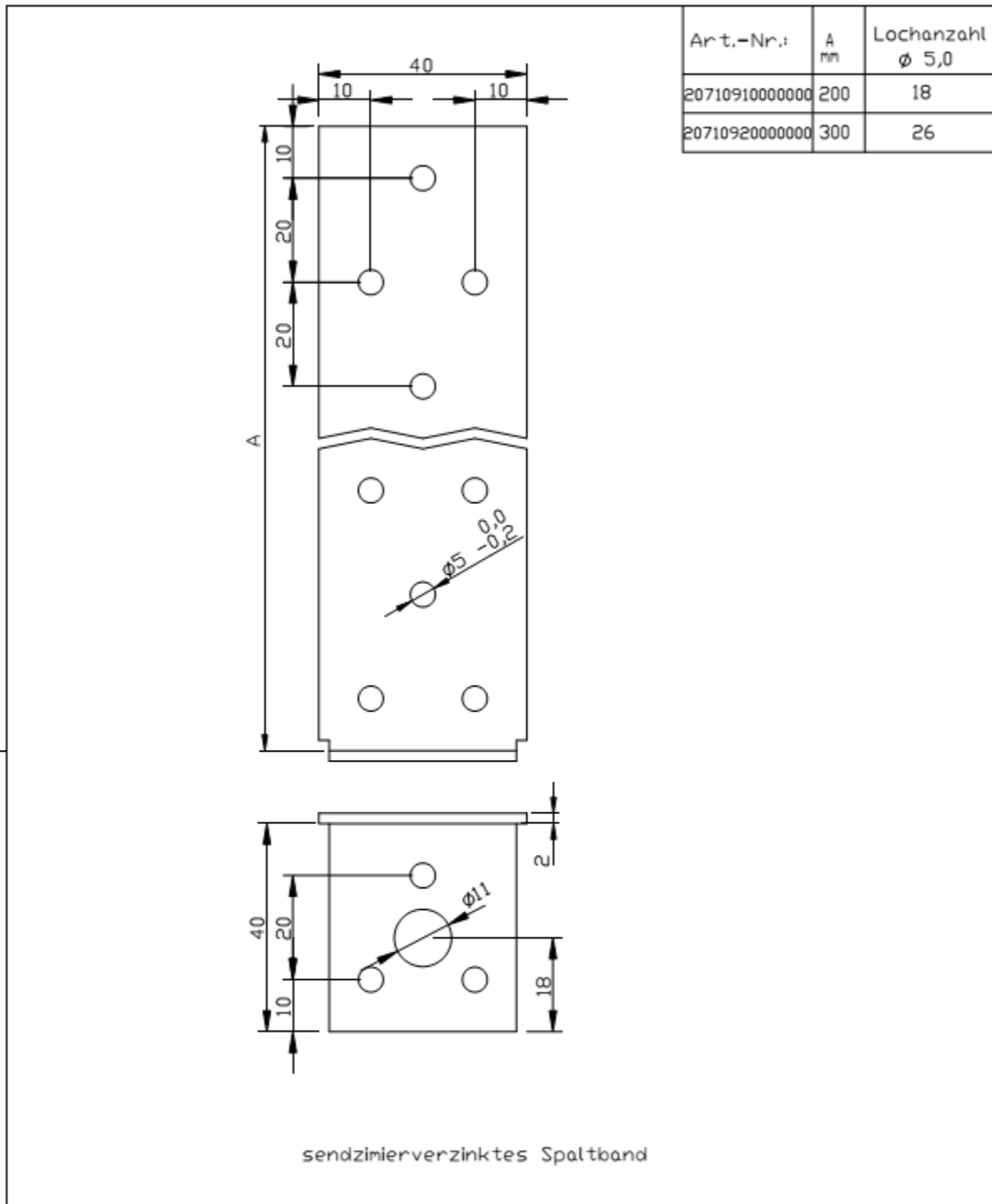

Art.-Nr.:	A mm	Lochanzahl Ø 5,0
20710910000000	200	18
20710920000000	300	26

sendzimiervverzinktes Spaltband

Kunde: August Vormann GmbH & Co. 58256 Ennepetal Kundennr.: xx		Material: xx B x S : xx VS : 40		Maßstab 1:1		Format A 4	
				Code: /z/hv/71091-1			
A r t i k e l							
				Beton-Flachstahl- anker			
				Art.Nr.71091/71092			
				Blatt x			
① war 71091 bzw. 71092		10.06.89 Richter		VORMANN Scharniere & Beschläge			
Zust.	Änderung	Datum	Name				

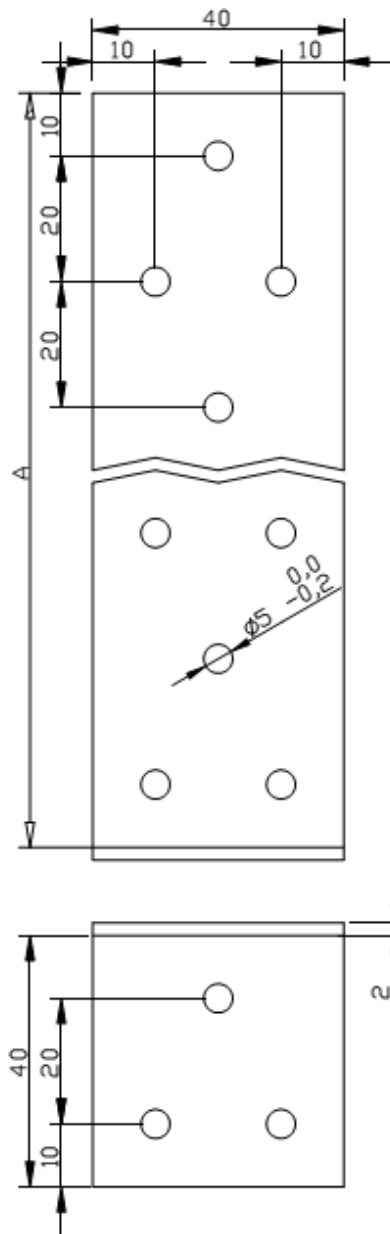

Art.-Nr.:	A mm	Lochanzahl ø 5,0
20710930000000	400	33

sendzimirverzinktes Spaltband

Kunde: August Vormann GmbH & Co. 58256 Ennepetal Kundennr.: xx		Material: xx B x S : xx VS : 40		Maßstab 1:1	Format A 4
				Code: /z/hv/71093-1	
				A r t i k e l	
				Beton-Flachstahl- anker	
				Art.Nr. 71093	
				Blatt x	
Zust.	Änderung	Datum	Name		

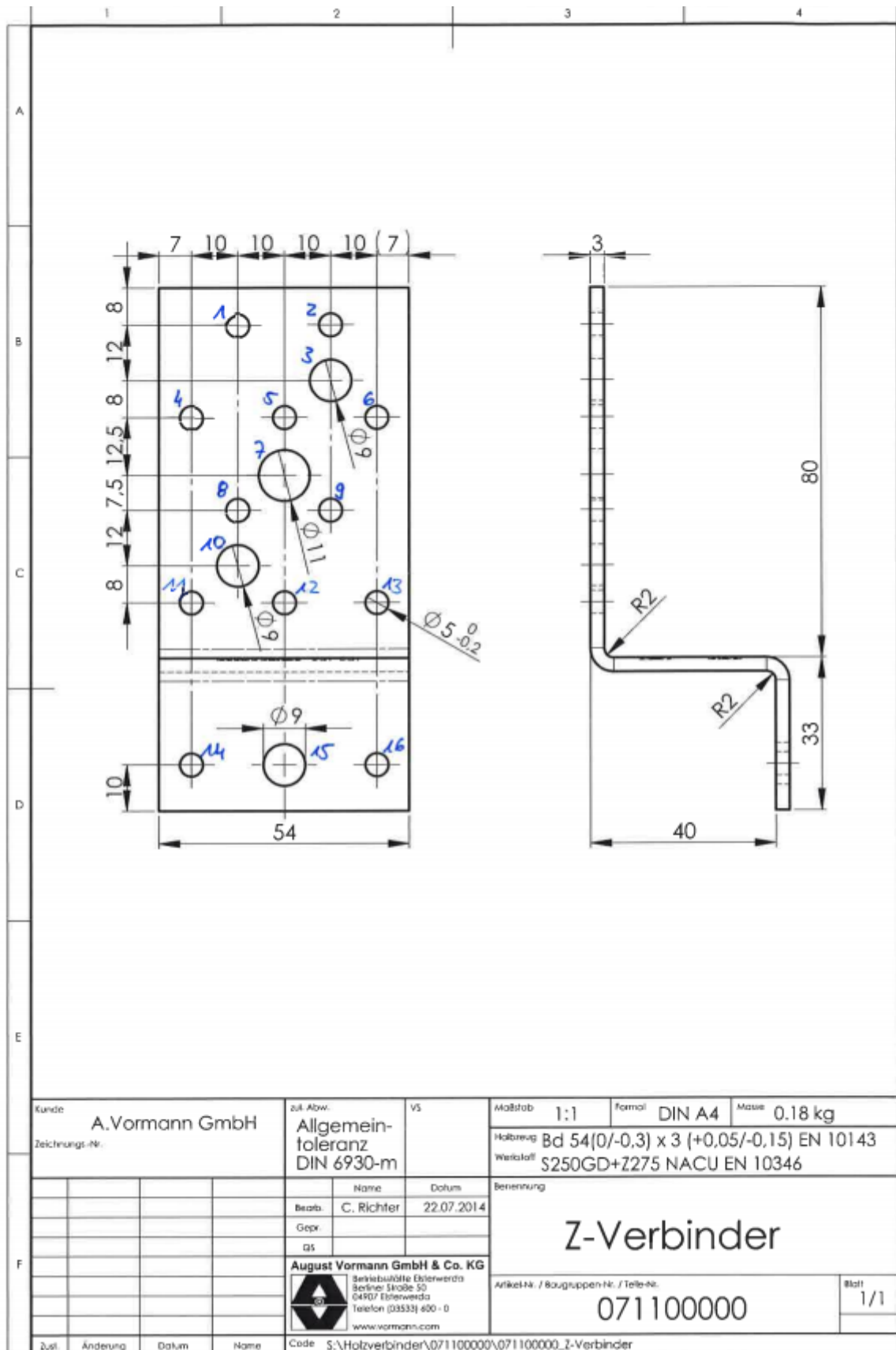

Kunde A.Vormann GmbH		zu Abw. Allgemein- toleranz DIN 6930-m		VS	Maßstab 1:1	Formal DIN A4	Masse 0.18 kg
Zeichnungs-Nr.					Holzbrug Bd 54(0/-0,3) x 3 (+0,05/-0,15) EN 10143		
					Verleimstoff S250GD+Z275 NACU EN 10346		
		Name Datum		Benennung			
		Bezirb. C. Richter 22.07.2014		Z-Verbinder			
		Gepr.					
		QS		Artikel-Nr. / Baugruppen-Nr. / Teile-Nr. 071100000			
		August Vormann GmbH & Co. KG Betriebsstätte Eblenwerda Berliner Straße 50 04907 Eblenwerda Telefon (03533) 400 - 0 www.vormann.com					
Zust.	Änderung	Datum	Name	Code S:\Holzverbinder\071100000\071100000_Z-Verbinder			

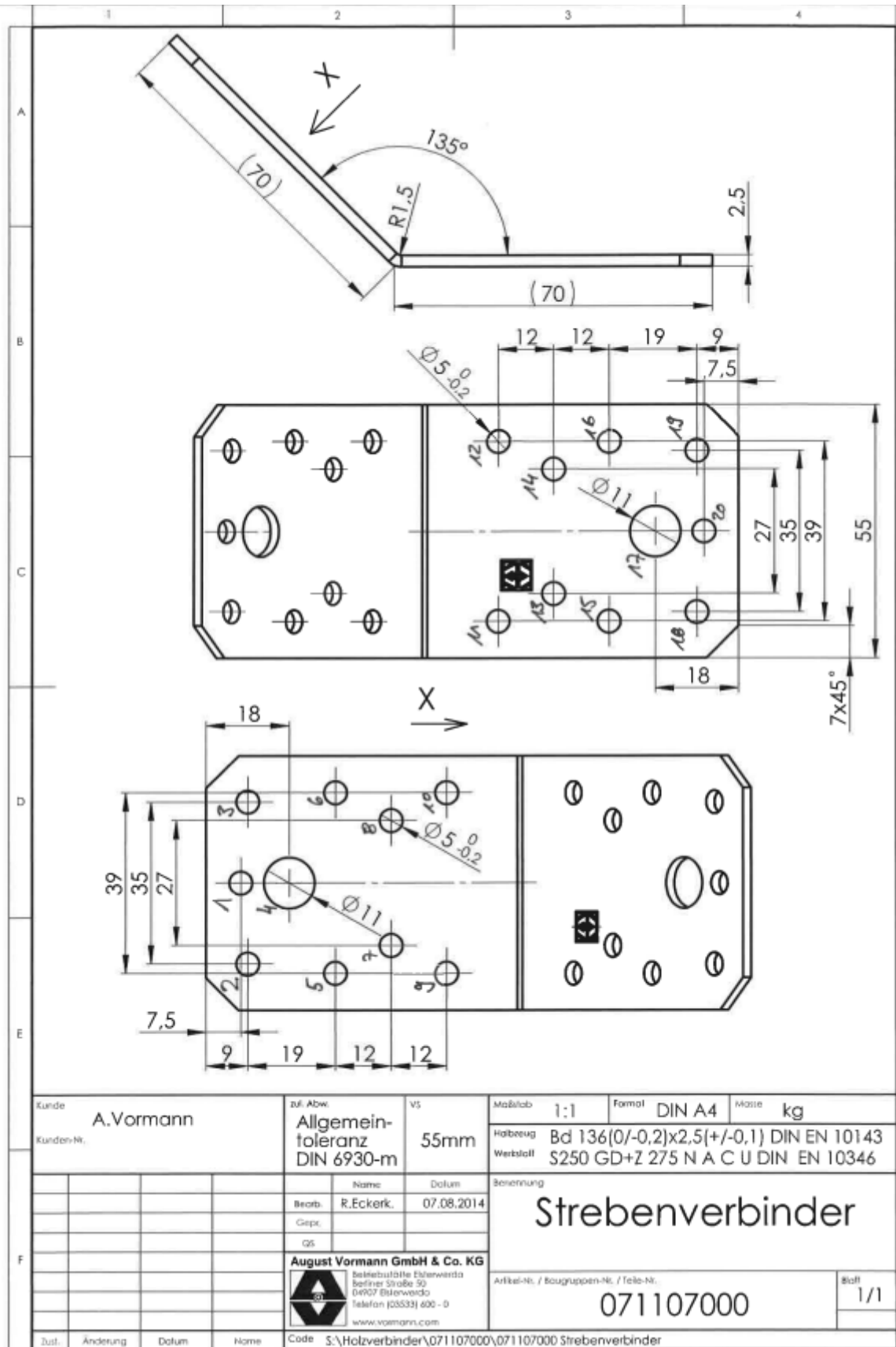

Kunde A.Vormann		Zvl. Abw. Allgemein- toleranz DIN 6930-m		VS 55mm	Maßstab 1:1	Format DIN A4	Masse kg
Kunden-Nr.		Name		Datum	Hohlboeg Bd 136(0/-0,2)x2,5(+/-0,1) DIN EN 10143		
		Bearb. R.Eckerk.		07.08.2014	Werkstoff S250 GD+Z 275 N A C U DIN EN 10346		
		Gepr.			Benennung Strebenverbinder		
		GS			Artikel-Nr. / Baugruppen-Nr. / Teile-Nr. 071107000		
		August Vormann GmbH & Co. KG Seinerstraße Eisenwerda 04907 Eisenwerda Telefon (03533) 600-0 www.vormann.com			Blatt 1/1		
Zust.	Änderung	Datum	Name	Code S:\Holzverbinder\071107000\071107000 Strebenverbinder			

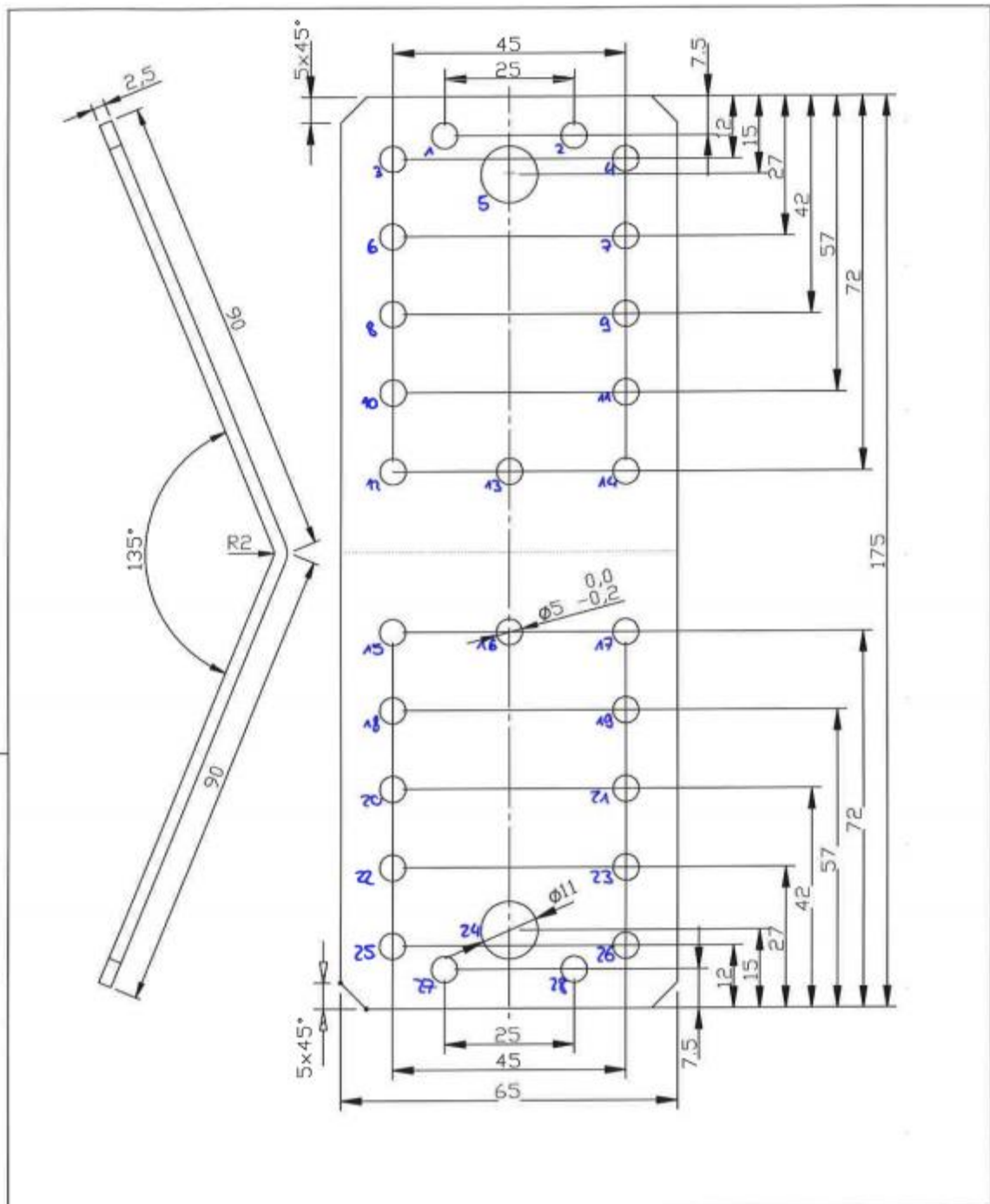

Kunde: August Vormann GmbH & Co. 58256 Ennepetal		Material: S250 GD+Z 275		Maßstab: 1:1	Format: A 4
Kundennr.: xx		B x S : 175x2,5 VS : 65		Code: /z/hvl/71100-1	
A r t i k e l					
Winkelverbinder					
X					
Art.Nr.: 71108					
Blatt x					
Zust.	Änderung	Datum	Name		

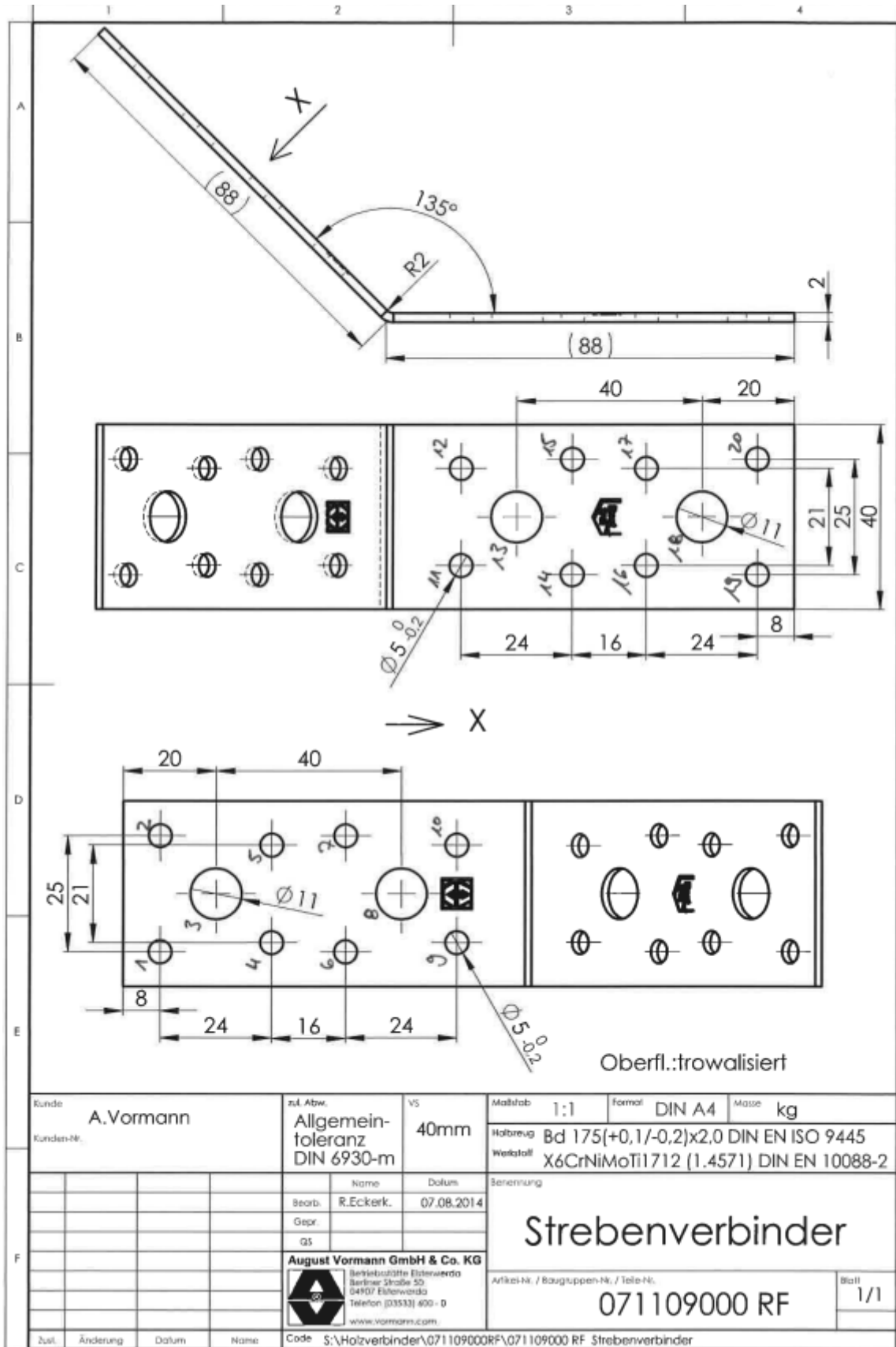

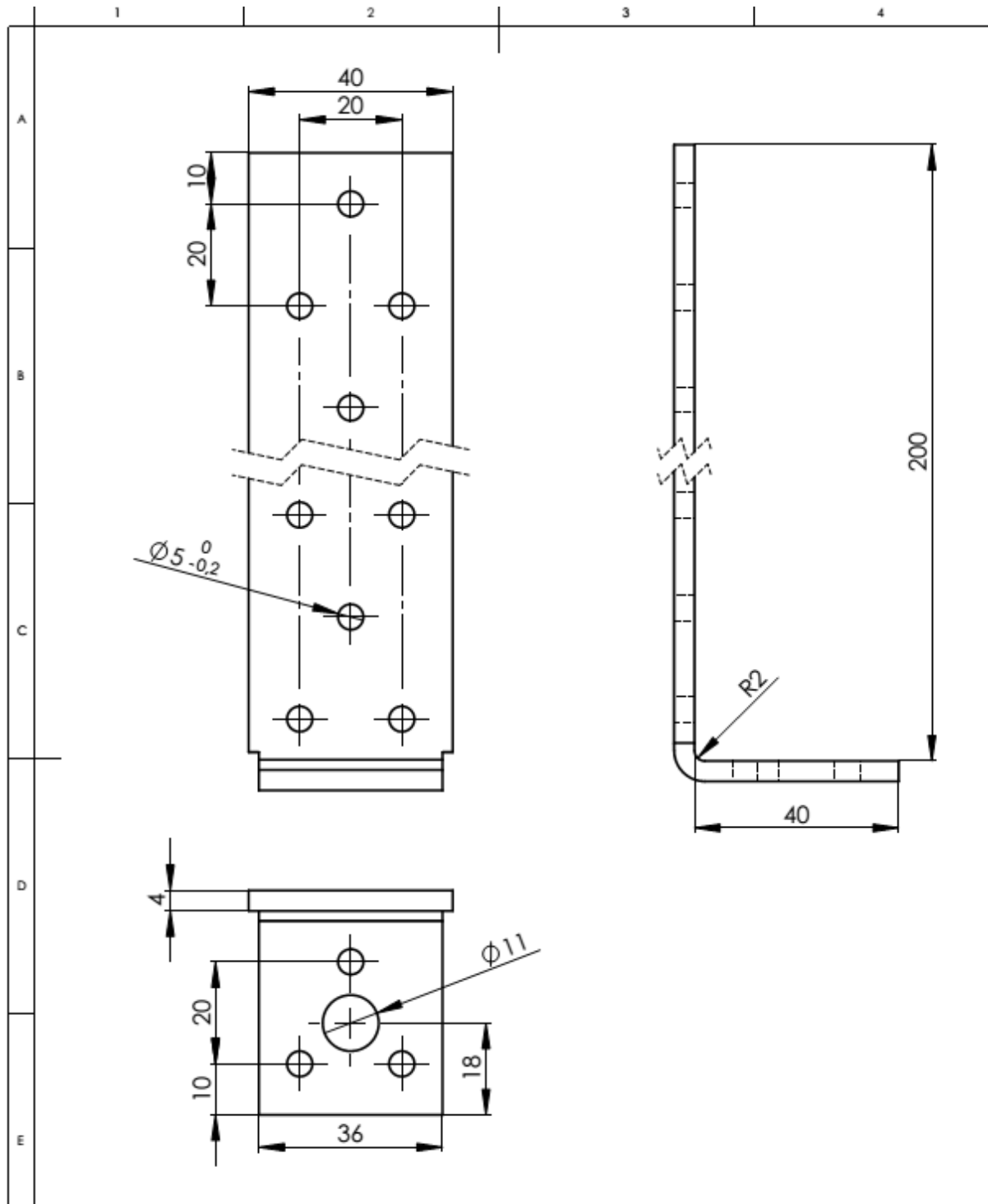

Kunde A.Vormann		zul. Abw. Allgemein- toleranz DIN 6930-m		VS 40mm	Maßstab 1:1	Format DIN A4	Masse kg
Kunden-Nr.					Holzboag Bd 240(±0,15)x4(±0,13) EN 10143		
					Werkstoff S250GD+Z275 NACU EN 10346		
				Name	Benennung		
		Bearb. R.Eckerk.		Datum 12.01.2011	Beton-Flachstahllanker		
		Gepr.					
		QS					
				August Vormann GmbH & Co. KG			
				Betriebsstätte Eßlerwerda Berliner Straße 50 04907 Eßlerwerda Telefon (03533) 600 - 0			Artikelnr. / Baugruppen-Nr. / Teile-Nr.
							Blatt 1/1
				www.vormann.com			071191000
2	hinz.Ansicht	13.01.2011	R.Eckerk.				
1	war $\phi 4,8$	12.01.2011	R.Eckerk.				
Zust.	Änderung	Datum	Name	Code S:\Holzverbinder\071191000\071191000 Beton_Flachstahllanker			

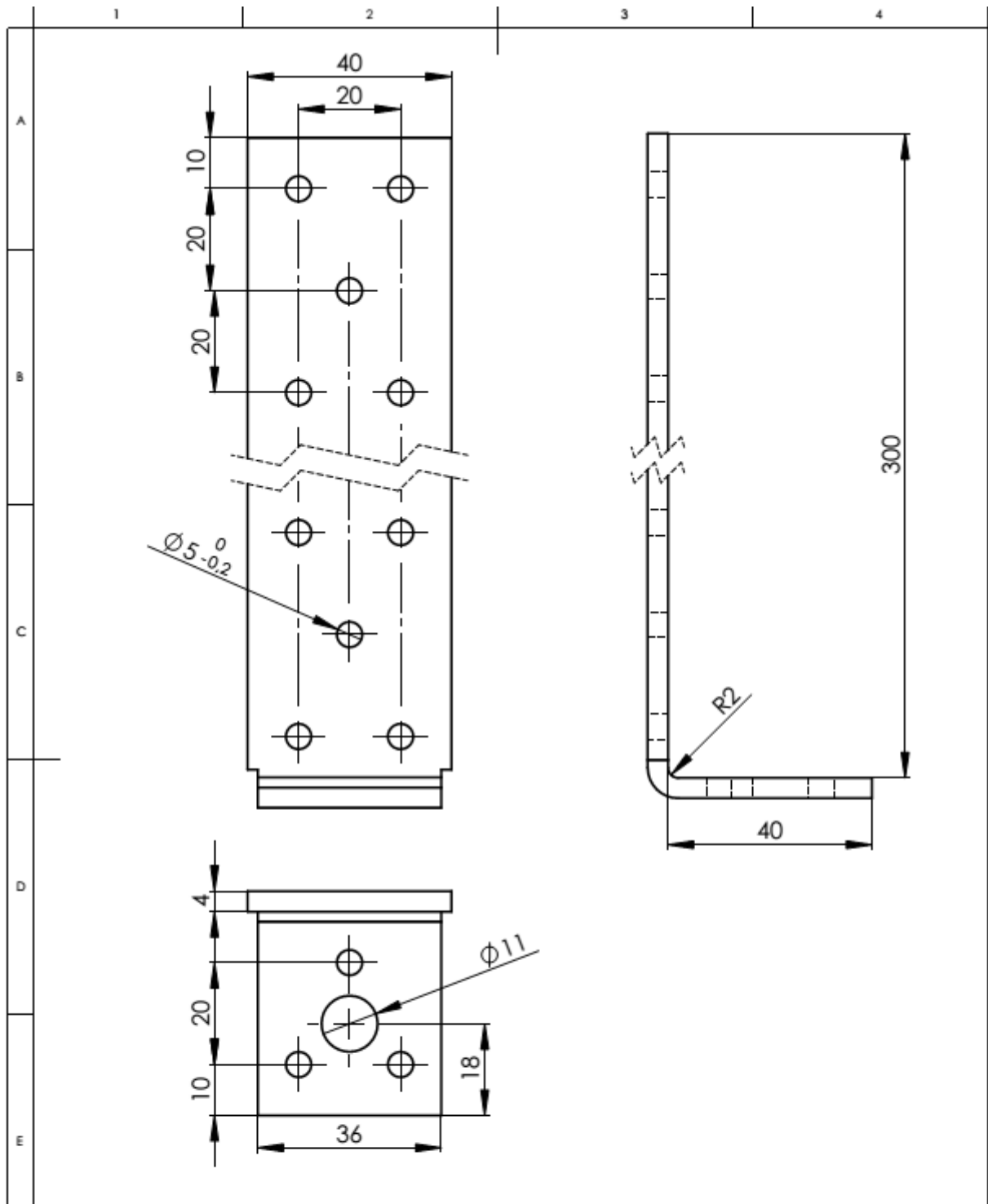

Kunde A.Vormann		zul. Abw. Allgemein- toleranz DIN 6930-m		VS 40mm	Maßstab 1:1	Format DIN A4	Masse kg
Kunden-Nr.					Holzboag Bd 340(±0,15)x4(±0,13) EN 10134		
					Werkstoff S250GD+Z275 NACU EN 10346		
					Benennung		
					Beton-Flachstahlanker		
					Artikel-Nr. / Baugruppen-Nr. / Teile-Nr.		
					071192000		
					Blatt 1/1		
2 hinz. Ansicht 13.01.2011 R.Eckerk.							
1 war $\phi 4,8$ 12.01.2011 R.Eckerk.							
zust. Änderung Datum Name							
				Code	S:\Holzverbinder\071192000\071192000 Beton_Flachstahlanker		

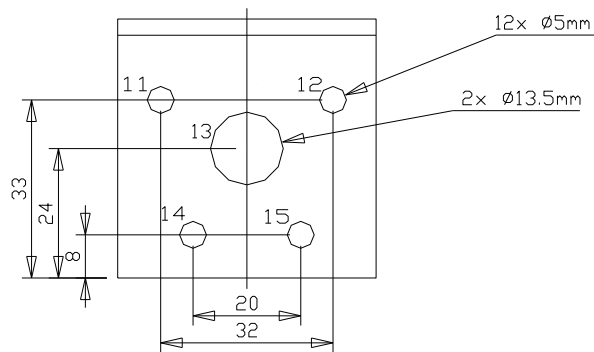
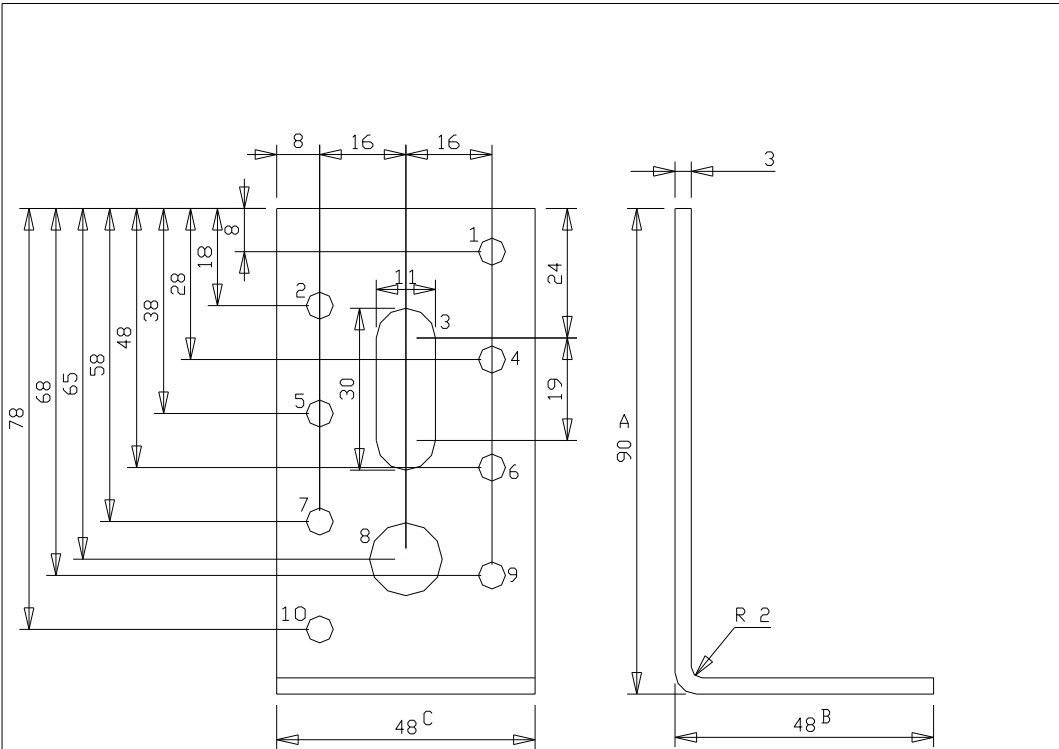

August Vormann
 GmbH&Co.KG
 Heilenbeckerstr.
 58256 Ennepetal

Winkelverbinder
 71194

Speicher Code: /z/hv1/71194so

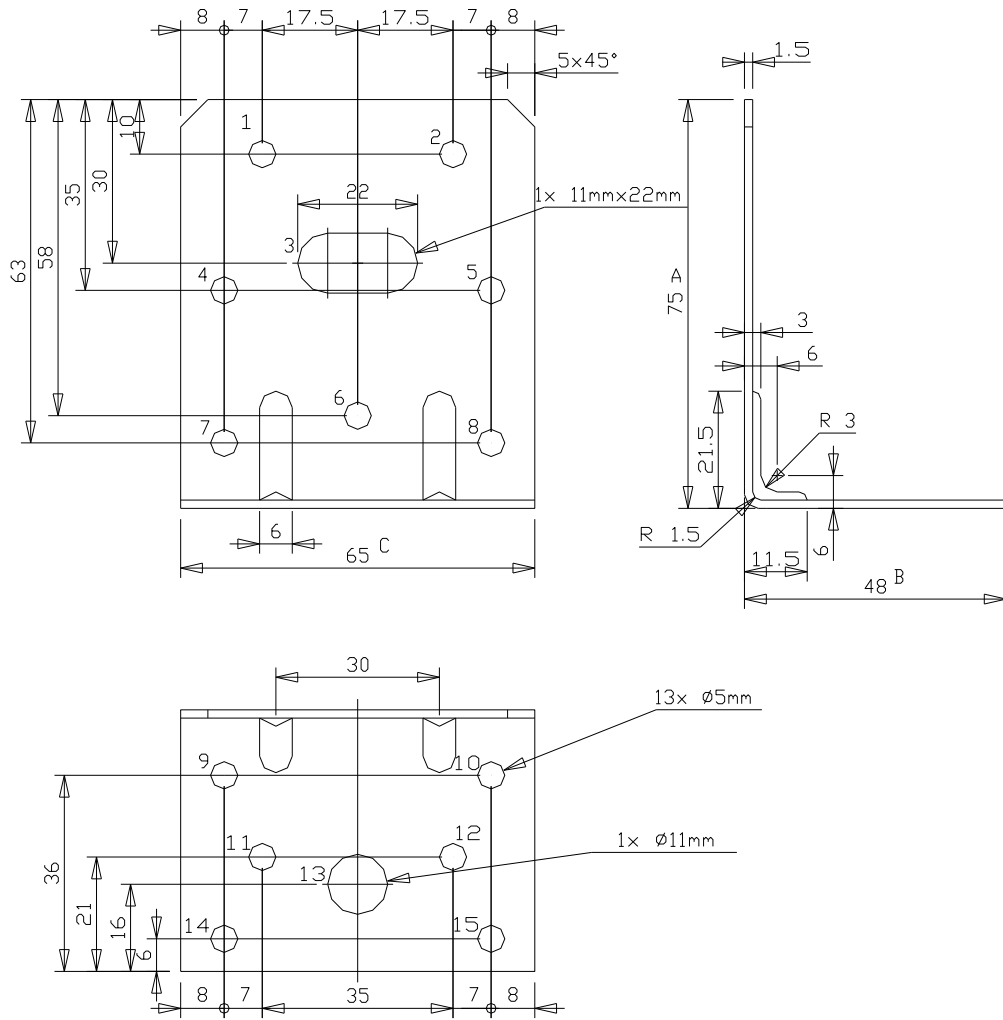

August Vormann
GmbH&Co.KG
Heilenbeckerstr.
58256 Ennepetal

Winkelverbinder
71194015

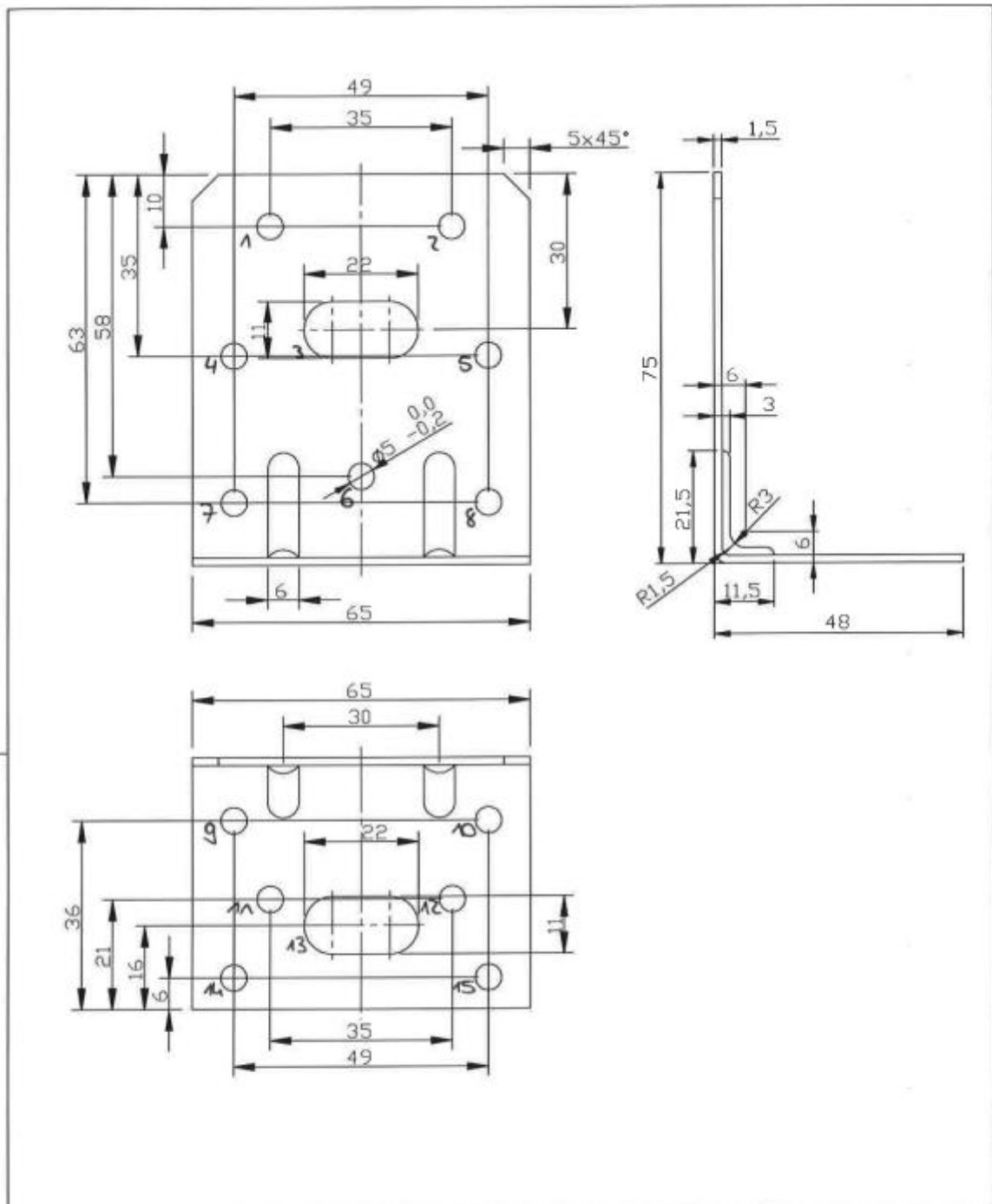

Kunde: x		Material: S250 GD+Z 275		Maßstab 1:1		Format A 4	
Kundennr.: xx		B x S : 120x1,5		Code: /z/hv1/71194016-1			
		VS : 65		Artikel			
		Datum	Name	Winkelverbinder			
		Bearb.	01.03.10 Niebert				
		Gepr.					
		Name		X			
Freimaßtoleranzen DIN 6930 m							
		VORMANN		Art.Nr.:071194016 GP			Blatt x
		Schmiere & Beschläge					
②	entfernt	10.12.13	R.Eckerk				
①	Kennzeichg. Hinzugef.	18.03.10	Richter				
Zust.	Änderung	Datum	Name				

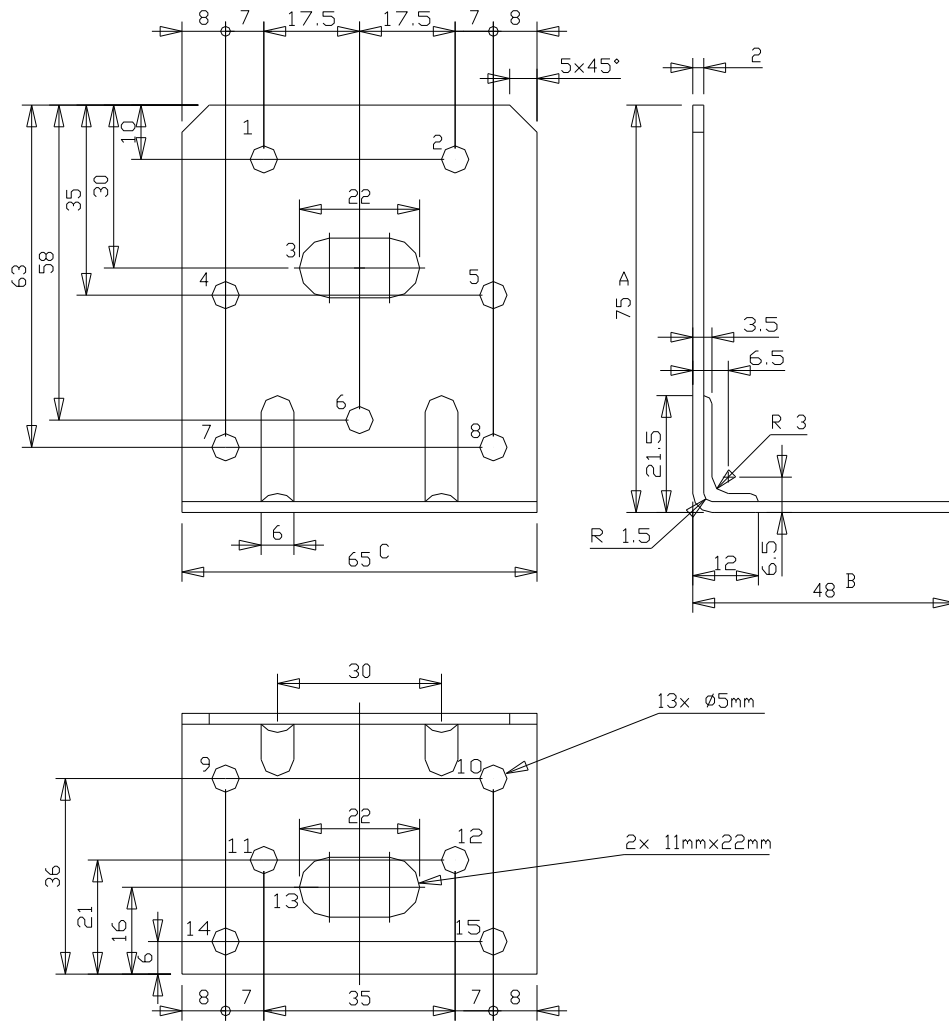

August Vormann
 GmbH&Co.KG
 Heilenbeckerstr.
 58256 Ennepetal

Winkelverbinder
 71194020

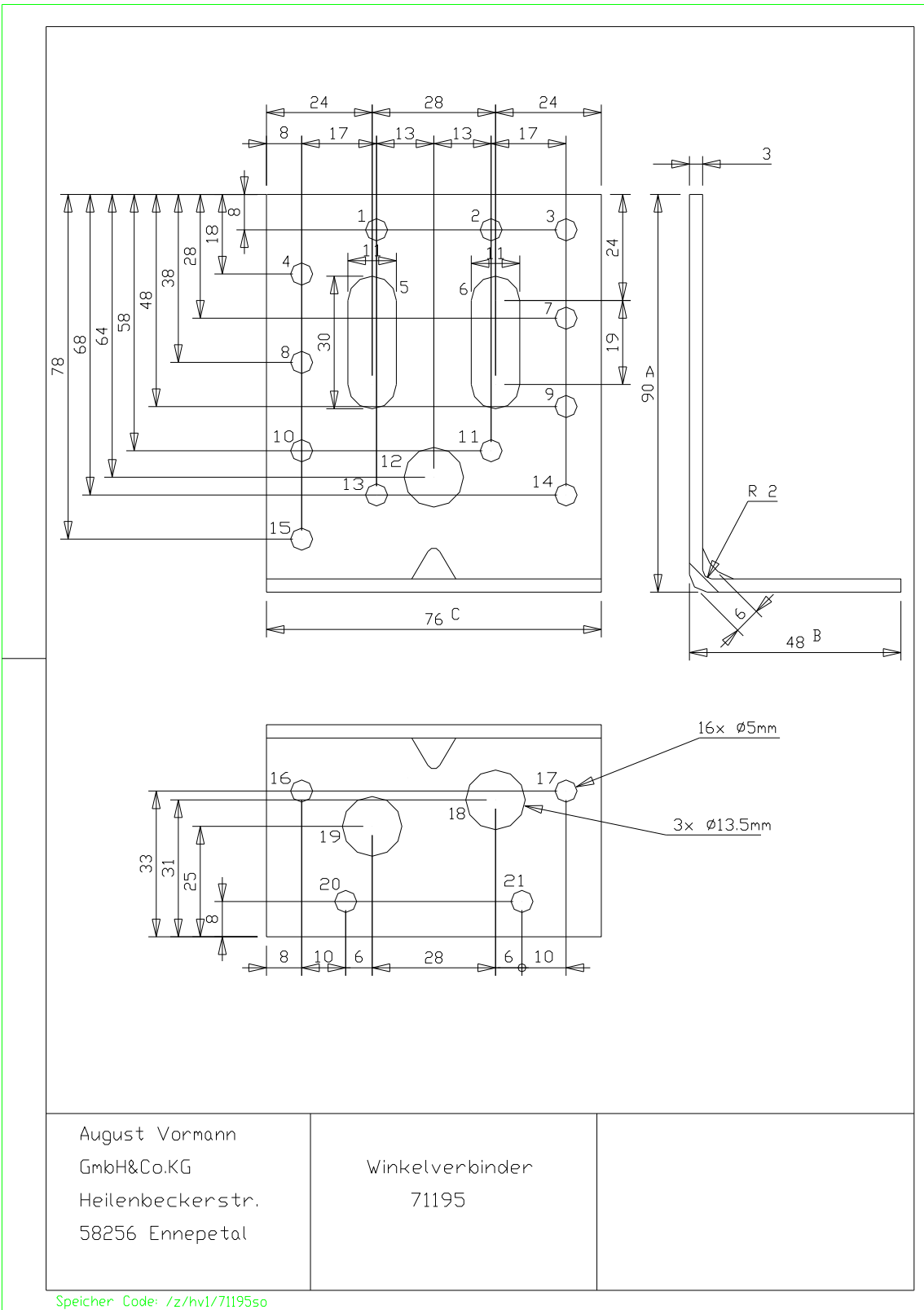

August Vornann
 GmbH&Co.KG
 Heilenbeckerstr.
 58256 Ennepetal

Winkelverbinder
 71195

Speicher Code: /z/hv1/71195so

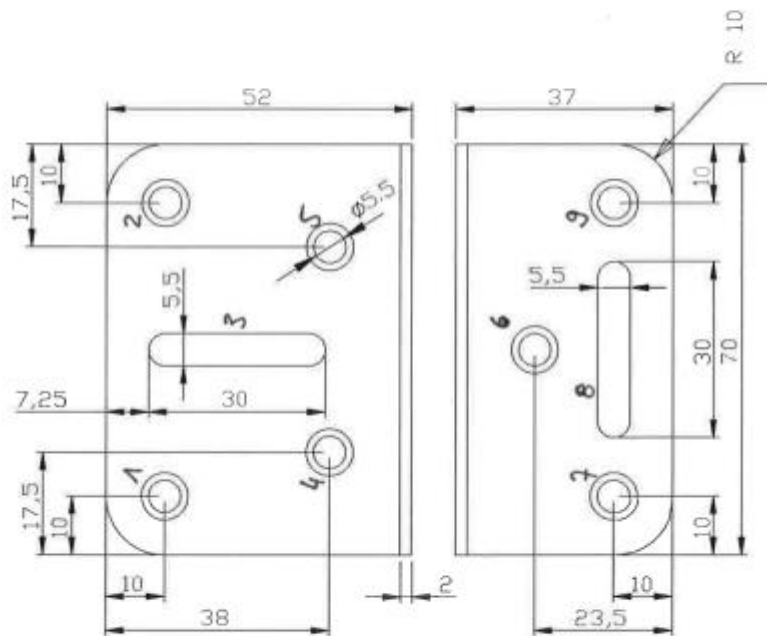

druckversenkt für Schraube $\varnothing 4\text{mm}$

Kunde: August Vormann GmbH & Co. 58256 Ennepetal Kundennr.: xx		Material: 1.4571 B x S : 90x2 VS : 73,5		Maßstab 1:1	Format A 4
				Code: /z/hv/71200rf-1	
				A r t i k e l	
				Vario-Winkel- verbinder	
				Art.Nr.: 71200rf	
				Blatt x	
Zust.	Änderung	Datum	Name		

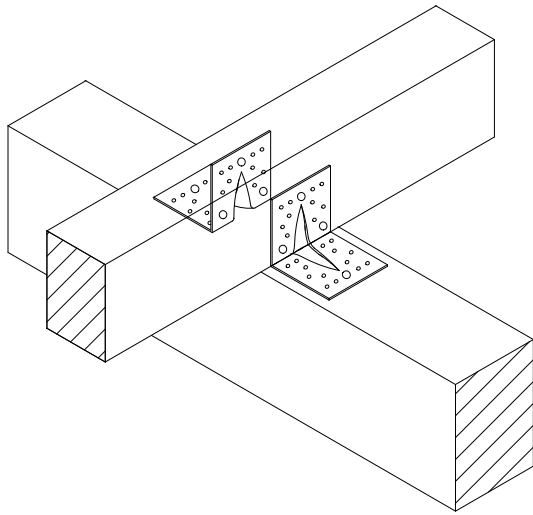

Figure A.1: Typical installation of angle brackets and hold-downs

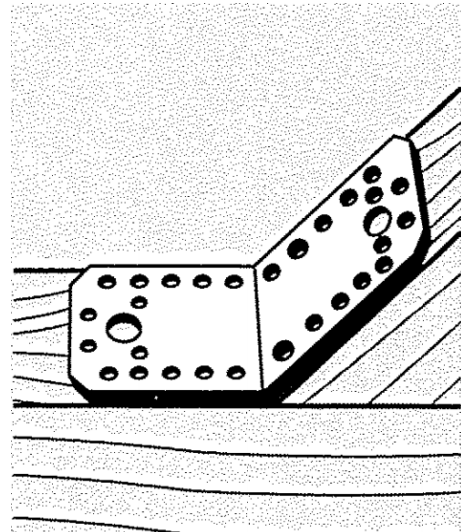

Figure A.2: Typical installation of brace connector

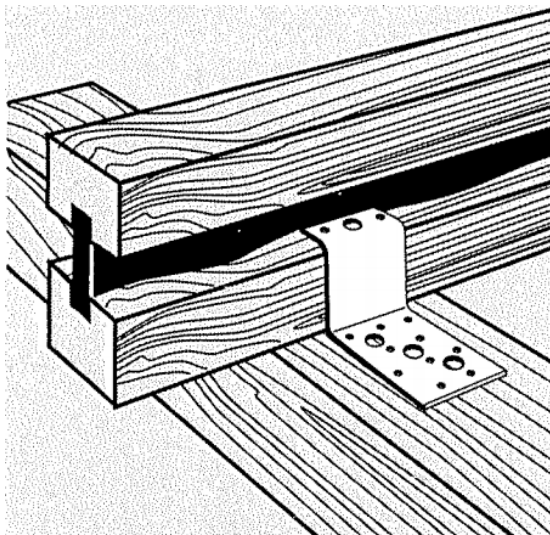

Figure A.3: Typical installation of a Z-connector

Annex B
Characteristic load-carrying capacities

The following tables contain the characteristic values for the load carrying capacities of the brackets for the column or purlin and beam connections. The minimum rated value resulting from timber failure and steel failure is applicable. It must be ensured that the timber members are restrained against rotation. The hole numbers specified must be provided with nails.

The values in the following tables are valid for threaded nails 4,0 x 40 mm with $F_{ax,Rk} = 686$ N and $M_{y,Rk} = 6617$ Nmm.

S 250 GD / Z275 Steel angle brackets

Table 1: Force F_1 Column, 2 angle brackets / connection, Timber to timber

Bracket number	Nail number n_V	Nail number n_H	$F_{1,Rk}$ [kN] (column)	
			Timber	Steel
070 904 000 40x40x40x2,0	-	-	-	-
070 905 000 50x50x40x2,0	-	-	-	-
070 912 000 60x40x60x2,5	1,2,3	10,11,12,14,15	2,83	2,50
070 913 000 80x60x60x2,5	1,2,3,4,6	12,13,15,17,19,20	2,37	3,02
070 914 000 100x60x60x2,5	1,2,3,5,6,7,8	15,16,18,20,22,23	2,37	3,02
070 914 040 100x60x40x2,5	1,2,3,4,5,6	11,12,13,14,15,16	2,54	2,43
070 915 000 90x60x60x2,5	1,2,3,4,5	12,13,14,15	1,86	1,35
070 916 000 60x35x60x2,5	-	-		
070 917 000 120x90x40x4,0	1,2,4,5,7,8	14,15,16,17,19,20,21,22	2,41	3,20
070 918 000 90x35x40x2,5	1,2,4,5	11,13,14	1,47	0,91
070 919 000 110x35x40x2,5	1,2,6,7	13,15,16	1,47	0,91
070 920 000 140x35x40x2,5	1,2,4,5,6,7,8,9	16,18,19	1,47	0,91
070 922 000 52x52x40x2,5	-	-	-	-
070 934 000 40x40x60x2,5	-	-	-	-
070 935 000 60x60x40x2,5	1,2	7,8,9,10,11,12	2,42	1,98
070 935 020 60x60x40x2,0	1,2	7,8,9,10,11,12	2,42	1,26

070 936 000 60x60x50x2,5	1,2	7,8,9,10,11,12	2,42	2,64
070 937 000 60x60x60x2,5	1,2	9,10,11,12,13,14,15,16	2,54	4,06
070 938 000 60x60x80x2,5	1,2	11,12,13,14,15,16,17,18,19,20	2,54	5,68
070 940 000 80x80x60x2,5	1,2,3,4,5	12,13,14,15,16,17,18,19,20,21,22	2,67	4,05
070 941 000 80x80x80x2,5	1,2,3,4,5,6	15,16,17,18,19,20,21,22,23,24,25,26, 27,28	2,67	5,68
070 942 000 70x50x40x2,0	1,2,3	9,10,11,12,13	2,24	1,18
070 943 000 100x100x60x2,5	1,2,3,4,5,6,7,8	15,16,17,18,19,20,21,22,23,24,25,26, 27,28	2,75	4,05
070 944 000 100x100x80x2,5	1,2,3,4,5,6,7,8,9,10	19,20,21,22,23,24,25,26,27,28,29,30, 31,32,33,34,35,36	2,75	5,68
070 945 000 100x100x100x2,5	1,2,3,4,5,6,7,8,9,10,11,12,13	24,25,26,27,28,29,30,31,32,33,34,35, 36,37,38,39,40,41,42,43,44,45,46	4,12	6,89
071 084 000 75x75x40x2,0	1,2	6,7,8,9,10	1,95	0,60
071 085 000 100x100x40x2,0	1,2,3	9,10,11,12,13,14,15,16	2,57	1,03
071 086 000 125x125x40x2,0	1,2,3,4,5	10,11,12,13,14,15,16,17,18	1,32	1,09
071 086 150 150x150x65x2,5	1,2,3,4,5,6,7,8,9,10,11,12,13, 14,15	23,24,25,26,27,28,29,30,31,32,33,34, 35,36,37,38,39,40,41,42	2,64	2,08
071 087 000 42x42x100x2,0	-	-	-	-
071 088 000 42x42x160x2,0	-	-	-	-
071 089 000 60x60x100x2,5	1,2,3	14,15,16,17,18,19,20,21,22,23,24,25,26	3,81	6,89
071 090 000 80x80x100x2,5	1,2,3,4,5,6,7,8	19,20,21,22,23,24,25,26,27,28,29,30, 31,32,33,34,35, 36	4,07	6,89
071 194 000 90x48x48x3,0	1,2,4,5	11,12,14,15	2,04	2,87
071 194 015 75x48x65x1,5	1,2	9,10,14,15	2,22	1,25
071 194 016 GP 75x48x65x1,5	1,2	9,10,14,15	2,19	1,29
071 194 020 75x48x65x2,0	1,2	9,10,14,15	2,22	2,27
071 195 000 90x48x76x3,0	1,2,3,4,7,8	16,17,20,21	2,04	3,97

The table contains the characteristic values of the load carrying capacity for a column connection. Values must be halved for one

joint per connection.

Table 2: Force F_1 Purlin, 2 angle brackets / connection, Timber to timber

Bracket number	Nail number n_V	Nail number n_H	$F_{1,Rk}$ [kN] (column)	
			Timber	Steel
070 904 000 40x40x40x2,0	1,2	5,6,7,8	2,05	1,24
070 905 000 50x50x40x2,0	1,2,3	6,7,8,9,10	2,24	1,18
070 912 000 60x40x60x2,5	1,2,3,4,6	10,11,12,14,15	2,83	2,50
070 913 000 80x60x60x2,5	1,2,3,4,6,7,8	12,13,15,17,19,20	2,37	3,02
070 914 000 100x60x60x2,5	1,2,3,5,6,7,8,10,11	15,16,18,20,22,23	2,37	3,02
070 914 040 100x60x40x2,5	1,2,3,4,5,6,7,8	11,12,13,14,15,16	2,54	2,43
070 915 000 90x60x60x2,5	1,2,3,4,5,6,7	12,13,14,15	1,86	1,35
070 916 000 60x35x60x2,5	-	-	-	-
070 917 000 120x90x40x4,0	1,2,4,5,7,8,9,10	14,15,16,17,19,20,21,22	2,41	3,20
070 918 000 90x35x40x2,5	1,2,4,5,6,7	11,13,14	1,47	0,91
070 919 000 110x35x40x2,5	1,2,6,7,8,9	13,15,16	1,47	0,91
070 920 000 140x35x40x2,5	1,2,4,5,6,7,8,9,11,12	16,18,19	1,47	0,91
070 922 000 52x52x40x2,5	1,2	6,7,9,10	1,75	1,17
070 934 000 40x40x60x2,5	1,2	6,7,8,9,10	2,17	3,91
070 935 000 60x60x40x2,5	1,2,3,4	7,8,9,10,11,12	2,42	1,98
070 935 020 60x60x40x2,0	1,2,3,4	7,8,9,10,11,12	2,42	1,26
070 936 000 60x60x50x2,5	1,2,3,4	7,8,9,10,11,12	2,42	2,64
070 937 000 60x60x60x2,5	1,2,3,4,5	9,10,11,12,13,14,15,16	2,54	4,06
070 938 000 60x60x80x2,5	1,2,3,4,5,6	11,12,13,14,15,16,17,18,19,20	2,54	5,68

070 940 000 80x80x60x2,5	1,2,3,4,5,6,7,8	12,13,14,15,16,17,18,19,20,21,22	2,67	4,05
070 941 000 80x80x80x2,5	1,2,3,4,5,6,7,8,9,10	15,16,17,18,19,20,21,22,23,24,25,26, 27,28	2,67	5,68
070 942 000 70x50x40x2,0	1,2,3,4,5	9,10,11,12,13	2,24	1,18
070 943 000 100x100x60x2,5	1,2,3,4,5,6,7,8,9,10,11	15,16,17,18,19,20,21,22,23,24,25,26, 27,28	2,75	4,05
070 944 000 100x100x80x2,5	1,2,3,4,5,6,7,8,9,10,11,12,13,14	19,20,21,22,23,24,25,26,27,28,29,30, 31,32,33,34,35,36	2,75	5,68
070 945 000 100x100x100x2,5	1,2,3,4,5,6,7,8,9,10,11,12,13,1 4,15,16,17,18	24,25,26,27,28,29,30,31,32,33,34,35, 36,37,38,39,40,41,42,43,44,45,46	4,12	6,89
071 084 000 75x75x40x2,0	1,2,3,4,5	6,7,8,9,10	1,95	0,60
071 085 000 100x100x40x2,0	1,2,3,4,5,6	9,10,11,12,13,14,15,16	2,57	1,03
071 086 000 125x125x40x2,0	1,2,3,4,5,6,7,8	10,11,12,13,14,15,16,17,18	1,32	1,09
071 086 150 150x150x65x2,5	1,2,3,4,5,6,7,8,9,10,11,12,13, 14,15,16,17,18	23,24,25,26,27,28,29,30,31,32,33,34, 35,36,37,38,39,40,41,42	2,64	2,08
071 087 000 42x42x100x2,0	1,2,3	9,10,11,12,13,14,15,16	3,08	3,54
071 088 000 42x42x160x2,0	1,2,3,4	13,14,15,16,17,18,19,20,21,22,23,24	4,11	5,83
071 089 000 60x60x100x2,5	1,2,3,4,5,8,7,8	14,15,16,17,18,19,20,21,22,23,24,25,26	3,81	6,89
071 090 000 80x80x100x2,5	1,2,3,4,5,6,7,8,9,10,11,12,13	19,20,21,22,23,24,25,26,27,28,29,30, 31,32,33,34,35, 36	4,07	6,89
071 194 000 90x48x48x3,0	1,2,4,5,6	11,12,14,15	2,04	2,87
071 194 015 75x48x65x1,5	1,2,4,5	9,10,14,15	2,22	1,25
071 194 016 GP 75x48x65x1,5	1,2,4,5	9,10,14,15	2,19	1,29
071 194 020 75x48x65x2,0	1,2,4,5	9,10,14,15	2,24	2,27
071 195 000 90x48x76x3,0	1,2,4,7,8,9,10,11	16,17,20,21	2,04	3,97

The table contains the characteristic values of the load carrying capacity for a purlin connection. Values must be halved for one joint per connection.

Table 3: Forces $F_{2,3}$, 2 angle brackets / connection, Timber to timber

Bracket number	Nail number n_V	Nail number n_H	$F_{2,3,Rk}$ [kN]	
			Timber	

070 904 000 40x40x40x2,0	1,2	5,6,7,8	3,52
070 905 000 50x50x40x2,0	1,2,3	6,7,9,10	3,59
070 912 000 60x40x60x2,5	1,2,4,6	10,11,12,14,15	6,11
070 913 000 80x60x60x2,5	1,2,3,4,6,7,8	12,13,15,17,19,20	7,30
070 914 000 100x60x60x2,5	1,2,3,5,6,7,8,10,11	15,16,18,20,22,23	7,93
070 914 040 100x60x40x2,5	1,2,3,4,5,6,7,8	11,12,13,14,15,16	6,56
070 915 000 90x60x60x2,5	1,2,3,4,5,6,7	12,13,14,15	5,70
070 916 000 60x35x60x2,5	-	-	-
070 917 000 120x90x40x4,0	1,2,4,5,7,8,9,10	14,15,16,17,19,20,21,22	6,08
070 918 000 90x35x40x2,5	1,2,4,5,6,7	11,13,14	3,26
070 919 000 110x35x40x2,5	1,2,6,7,8,9	13,15,16	3,27
070 920 000 140x35x40x2,5	1,2,4,5,6,7,8,9,11,12	16,18,19	3,27
070 922 000 52x52x40x2,5	1,2	6,7,9,10	2,81
070 934 000 40x40x60x2,5	1,2	6,7,8,9,10	5,47
070 935 000 60x60x40x2,5	1,2,3	6,7,9,10	5,97
070 935 020 60x60x40x2,0	1,2,3,4	7,8,9,10,11,12	5,09
070 936 000 60x60x50x2,5	1,2,3,4	7,8,9,10,11,12	5,09
070 937 000 60x60x60x2,5	1,2,3,4	7,8,9,10,11,12	5,09
070 938 000 60x60x80x2,5	1,2,3,4,5,6	9,10,11,12,13,14,15,16	8,26
070 940 000 80x80x60x2,5	1,2,3,4,5,6	11,12,13,14,15,16,17,18,19,20	9,72
070 941 000 80x80x80x2,5	1,2,3,4,5,6,7,8	12,13,14,15,16,17,18,19,20,21,22	9,08
070 942 000 70x50x40x2,0	1,2,3,4,5,6,7,8,9,10,11,12	15,16,17,18,19,20,21,22,23,24,25,26, 27,28	15,05

070 943 000 100x100x60x2,5	1,2,3,4,5,6	9,10,11,12,13	4,81
070 944 000 100x100x80x2,5	1,2,3,4,5,6,7,8,9,10,11	15,16,17,18,19,20,21,22,23,24,25,26, 27,28	11,4
070 945 000 100x100x100x2,5	1,2,3,4,5,6,7,8,9,10,11,12,13, 14,15,16	19,20,21,22,23,24,25,26,27,28,29,30, 31,32,33,34,35,36	17,63
071 084 000 75x75x40x2,0	1,2,3,4,5,6,7,8,9,10,11,12,13, 14,15,16,17,18,19,20	24,25,26,27,28,29,30,31,32,33,34,35, 36,37,38,39,40,41,42,43,44,45,46	25,01
071 085 000 100x100x40x2,0	1,2,3,4,5	6,7,8,9,10	4,75
071 086 000 125x125x40x2,0	1,2,3,4,5,6	9,10,11,12,13,14,15,16	4,64
071 086 150 150x150x65x2,5	1,2,3,4,5,6,7,8	10,11,12,13,14,15,16,17,18	6,72
071 087 000 42x42x100x2,0	1,2,3,4,5,6,7,8,9,10,11,12,13, 14,15,16,17,18,19,20	23,24,25,26,27,28,29,30,31,32,33,34, 35,36,37,38,39,40,41,42	16,95
071 088 000 42x42x160x2,0	1,2,3	9,10,11,12,13,14,15,16	9,36
071 089 000 60x60x100x2,5	1,2,3,4	13,14,15,16,17,18,19,20,21,22,23, 24	13,00
071 090 000 80x80x100x2,5	1,2,3,4,5,8,7,8	14,15,16,17,18,19,20,21,22,23,24,25,26	16,39
071 194 000 90x48x48x3,0	1,2,3,4,5,6,7,8,9,10,11,12,13,14,15	19,20,21,22,23,24,25,26,27,28,29,30, 31,32,33,34,35, 36	20,95
071 194 015 75x48x65x1,5	1,2,4,5,6,7,9	11,12,14,15	5,18
071 194 016 GP 75x48x65x1,5	1,2,4,5	9,10,14,15	5,70
071 194 020 75x48x65x2,0	1,2,4,5	9,10,14,15	5,82
071 195 000 90x48x76x3,0	1,2,4,5	9,10,14,15	5,70
070 904 000 40x40x40x2,0	1,2,4,7,8,9,10,11,13,14	16,17,20,21	7,05

The table contains the characteristic values of the load carrying capacity for a purlin connection. Values must be halved for one joint per connection.

Table 4: Basic Forces $F_{4,5}$, 2 angle brackets / connection, Timber to timber

Bracket number	Nail number n_V	Nail number n_H	$F_{4,5,Rk}$ [kN]	
			Timber	Steel
070 904 000 40x40x40x2,0	1,2	5,6,7,8	7,42	1,72
070 905 000 50x50x40x2,0	1,2,3	6,7,8,9,10	8,81	1,53

070 912 000 60x40x60x2,5	1,2,4,6	10,11,12,14,15	5,75	4,04
070 913 000 80x60x60x2,5	1,2,3,4,6,7,8	12,13,15,17,19,20	6,00	3,94
070 914 000 100x60x60x2,5	1,2,3,5,6,7,8,10,11	15,16,18,20,22,23	6,39	3,55
070 914 040 100x60x40x2,5	1,2,3,4,5,6,7,8	11,12,13,14,15,16	5,37	2,44
070 915 000 90x60x60x2,5	1,2,3,4,5,6,7	12,13,14,15	6,05	3,61
070 916 000 60x35x60x2,5	-	-	-	-
070 917 000 120x90x40x4,0	1,2,4,5,7,8,9,10	14,15,16,17,19,20,21,22	6,18	4,29
070 918 000 90x35x40x2,5	1,2,4,5,6,7	11,13,14	5,29	2,58
070 919 000 110x35x40x2,5	1,2,6,7,8,9	13,15,16	5,86	2,45
070 920 000 140x35x40x2,5	1,2,4,5,6,7,8,9,11,12	16,18,19	5,29	2,10
070 922 000 52x52x40x2,5	1,2	6,7,9,10	3,96	1,22
070 934 000 40x40x60x2,5	1,2	6,7,8,9,10	5,38	3,25
070 935 000 60x60x40x2,5	1,2,3	6,7,8,9,10	3,42	2,99
070 935 020 60x60x40x2,0	1,2,3,4	7,8,9,10,11,12	5,11	2,26
070 936 000 60x60x50x2,5	1,2,3,4	7,8,9,10,11,12	5,20	1,71
070 937 000 60x60x60x2,5	1,2,3,4	7,8,9,10,11,12	5,50	2,82
070 938 000 60x60x80x2,5	1,2,3,4,5	9,10,11,12,13,14,15,16	6,74	3,22
070 940 000 80x80x60x2,5	1,2,3,4,5,6	11,12,13,14,15,16,17,18,19,20	7,81	4,23
070 941 000 80x80x80x2,5	1,2,3,4,5,6,7,8	12,13,14,15,16,17,18,19,20,21,22	6,67	3,45
070 942 000 70x50x40x2,0	1,2,3,4,5,6,7,8,9,10	15,16,17,18,19,20,21,22,23,24,25,26, 27,28	8,75	4,53
070 943 000 100x100x60x2,5	1,2,3,4,5,6	9,10,11,12,13	2,42	1,88
070 944 000 100x100x80x2,5	1,2,3,4,5,6,7,8,9,10,11	15,16,17,18,19,20,21,22,23,24,25,26, 27,28	7,26	3,40

070 945 000 100x100x1002,5	1,2,3,4,5,6,7,8,9,10,11,12,13, 14	19,20,21,22,23,24,25,26,27,28,29,30, 31,32,33,34,35,36	9,65	4,47
071 084 000 75x75x40x2,0	1,2,3,4,5,6,7,8,9,10,11,12,13, 14,15,16,17,18	24,25,26,27,28,29,30,31,32,33,34,35, 36,37,38,39,40,41,42,43,44,45,46	11,53	5,53
071 085 000 100x100x40x2,0	1,2,3,4,5	6,7,8,9,10	4,73	2,36
071 086 000 125x125x40x2,0	1,2,3,4,5,6	9,10,11,12,13,14,15,16	3,76	1,66
071 086 150 150x150x65x2,5	1,2,3,4,5,6,7,8	10,11,12,13,14,15,16,17,18	4,25	1,80
071 087 000 42x42x100x2,0	1,2,3,4,5,6,7,8,9,10,11,12,13, 14,15,16,17,18	23,24,25,26,27,28,29,30,31,32,33,34, 35,36,37,38,39,40,41,42	6,05	3,50
071 088 000 42x42x160x2,0	1,2,3	9,10,11,12,13,14,15,16	6,25	4,12
071 089 000 60x60x100x2,5	1,2,3,4	13,14,15,16,17,18,19,20,21,22,23,24	8,42	6,64
071 090 000 80x80x100x2,5	1,2,3,4,5,8,7,8	14,15,16,17,18,19,20,21,22,23,24,25,26	9,68	5,31
071 194 000 90x48x48x3,0	1,2,3,4,5,6,7,8,9,10,11,12,13	19,20,21,22,23,24,25,26,27,28,29,30, 31,32,33,34,35, 36	9,75	5,32
071 194 015 75x48x65x1,5	1,2,4,5,6	11,12,14,15	3,67	3,82
071 194 016 GP 75x48x65x1,5	-	-	-	-
071 194 020 75x48x65x2,0	1,2,4,5	9,10,14,15	4,81	1,96
071 195 000 90x48x76x3,0	1,2,4,5	9,10,14,15	5,61	2,83
070 904 000 40x40x40x2,0	1,2,4,7,8,9,10,11	16,17,20,21	6,93	6,15

The table contains the characteristic values of the load carrying capacity for a purlin connection. Load case $F_{4/5}$ describes a connection with two angle joints per connection. The component 2 is allowed to be restrained against rotation by the angle brackets. In this case, an additional force ΔF_1 has to be considered.

Stainless steel angle brackets

Table 5: Force F_1 Column, 2 angle brackets / connection, stainless steel, Timber to timber

Bracket number	Nail number n_V	Nail number n_H	$F_{1,Rk}$ [kN] (column)	
			Timber	Steel
070 904 000 40x40x40x2,0	-	-	-	-
070 905 000 50x50x40x2,0	-	-	-	-
070 934 000 40x40x60x2,0	-	-	-	-

070 935 000 60x60x40x2,0	-	-	-	-
070 935 000 60x60x40x2,5	1,2	7,8,9,10,11,12	2,42	1,19
070 937 000 60x60x60x2,0	-	-	-	-
070 937 000 60x60x60x2,5	1,2	9,10,11,12,13,14,15,16	2,54	2,42
071 200 000 (*) 52x37x70x2,0	-	-	-	-

The table contains the characteristic values of the load carrying capacity for a column connection. Values must be halved for one joint per connection.

(*) angle bracket with partially threaded screws ϕ 4,5x40 mm

Table 6: Force F_1 Purlin, 2 angle brackets / connection, stainless steel, Timber to timber

Bracket number	Nail number n_V	Nail number n_H	$F_{1,Rk}$ [kN] (purlin)	
			Timber	Steel
070 904 000 40x40x40x2,0	1,2	5,6,7,8	2,00	1,20
070 905 000 50x50x40x2,0	1,2,3	6,7,8,9,10	2,23	1,13
070 934 000 40x40x60x2,0	1,2	6,7,8,9,10	2,17	2,40
070 935 000 60x60x40x2,0	1,2,3,4	7,8,9,10,11,12	2,38	1,20
070 935 000 60x60x40x2,5	1,2,3,4	7,8,9,10,11,12	2,42	1,19
070 937 000 60x60x60x2,0	1,2,3,4,5	9,10,11,12,13,14,15,16	2,49	2,40
070 937 000 60x60x60x2,5	1,2,3,4,5	9,10,11,12,13,14,15,16	2,54	2,42
071 200 000 (*) 52x37x70x2,0	1,2	6,7,9	0,88	2,22

The table contains the characteristic values of the load carrying capacity for a purlin connection. Values must be halved for one joint per connection.

(*) angle bracket with partially threaded screws ϕ 4,5x40 mm

Table 7: Forces $F_{2,3}$, 2 angle brackets / connection, stainless steel, Timber to timber

Bracket number	Nail number n_V	Nail number n_H	$F_{2,3,Rk}$ [kN]
			Timber
070 904 000 40x40x40x2,0	1,2	5,6,7,8	3,75
070 905 000 50x50x40x2,0	1,2	6,7,9,10	3,59
070 934 000 40x40x60x2,0	1,2	6,7,8,9,10	5,50

070 935 000 60x60x40x2,0	1,2,3,4	7,8,9,10,11,12	5,16
070 935 000 60x60x40x2,5	1,2,3,4	7,8,9,10,11,12	5,09
070 937 000 60x60x60x2,0	1,2,3,4,5	9,10,11,12,13,14,15,16	7,96
070 937 000 60x60x60x2,5	1,2,3,4,5,6	9,10,11,12,13,14,15,16	8,26
071 200 000 (*) 52x37x70x2,0	1,2	6,7,9	4,09

The table contains the characteristic values of the load carrying capacity for a purlin connection. Values must be halved for one joint per connection.

(*) angle bracket with partially threaded screws ϕ 4,5x40 mm

Table 8: Basic Forces $F_{4,5}$, 2 angle brackets / connection, stainless steel, Timber to timber

Bracket number	Nail number n_V	Nail number n_H	$F_{4,5,Rk}$ [kN]	
			Timber	Steel
070 904 000 40x40x40x2,0	1,2	5,6,7,8	3,35	1,65
070 905 000 50x50x40x2,0	1,2,3	6,7,9,10	3,75	1,55
070 934 000 40x40x60x2,0	1,2	6,7,8,9,10	4,68	2,35
070 935 000 60x60x40x2,0	1,2,3,4	7,8,9,10,11,12	4,02	1,81
070 935 000 60x60x40x2,5	1,2,3,4	7,8,9,10,11,12	5,11	1,72
070 937 000 60x60x60x2,0	1,2,3,4,5	9,10,11,12,13,14,15,16	5,75	2,64
070 937 000 60x60x60x2,5	1,2,3,4,5	9,10,11,12,13,14,15,16	6,74	2,47
071 200 000 (*) 52x37x70x2,0	1,2	6,7,9	3,65	3,30

The table contains the characteristic values of the load carrying capacity for a purlin connection. Load case $F_{4/5}$ describes a connection with two angle joints per connection. The component 2 is allowed to be restrained against rotation by the angle brackets. In this case, an additional force ΔF_1 has to be considered.

(*) angle bracket with partially threaded screws ϕ 4,5x40 mm

S 250 GD / Z275 Steel brace connectors

Table 3: Force $F_{1,t}$ Column - tension, 1 brace connector / connection, Timber to timber

Bracket number	Nail number n_V	Nail number n_H	$F_{1,t,Rk}$ [kN] (column)	
			Timber	Steel
071 107 000 70x70x55x2,5	-	-	-	-

071 108 000 90x90x65x2,5	1,2	15,16,17,20,21,25,26	2,52	1,53
-----------------------------	-----	----------------------	------	------

To obtain design values of $F_{1,t,Rk}$ (steel) the particular partial factor γ_{M0} according to EN 1993 has to be applied.

Table 4: Force $F_{1,c}$ Column - compression, 1 brace connector / connection, Timber to timber

Bracket number	Nail number n_V	Nail number n_H	$F_{1,c,Rk}$ [kN] (column)	
			Timber	Steel
071 107 000 70x70x55x2,5	1,2,3	11,12,15,16,18,19,20	5,45	3,26
071 108 000 90x90x65x2,5	1,2,6,7	15,16,17,20,21,25,26	6,86	3,26

Table 7: Forces $F_{2,3}$, 1 brace connector / connection, Timber to timber

Bracket number	Nail number n_V	Nail number n_H	$F_{2,3,Rk}$ [kN] (column)
			Timber
071 107 000 70x70x55x2,5	1,2,3	11,12,15,16,18,19,20	2,03
071 108 000 90x90x65x2,5	1,2,6,7	15,16,17,20,21,25,26	2,45

Stainless steel brace connectors

Table 5: Force $F_{1,t}$ Column - tension, 1 brace connector / connection, stainless steel, Timber to timber

Bracket number	Nail number n_V	Nail number n_H	$F_{1,t,Rk}$ [kN] (column)	
			Timber	Steel
071 109 000 88x88x40x2,0	-	-	-	-

To obtain design values of $F_{1,t,Rk}$ (steel) the particular partial factor γ_{M0} according to EN 1993 has to be applied.

Table 6: Force $F_{1,c}$ Column - compression, 1 brace connector / connection, stainless steel, Timber to timber

Bracket number	Nail number n_V	Nail number n_H	$F_{1,c,Rk}$ [kN] (column)	
			Timber	Steel
071 109 000 88x88x40x2,0	1,2,4,5	11,12,14,15,19,20	4,34	2,20

To obtain design values of $F_{1,c,Rk}$ (steel) the particular partial factor γ_{M1} according to EN 1993 has to be applied.

Table 7: Forces $F_{2,3}$, 1 brace connector / connection, stainless steel, Timber to timber

Bracket number	Nail number n_V	Nail number n_H	$F_{2,3,Rk}$ [kN] (column)
			Timber
071 109 000 88x88x40x2,0	1,2,4,5	11,12,14,15,19,20	1,91

S 250 GD / Z275 Steel Z-connectors**Table 7:** Force F_1 Purlin, 2 Z-connectors / connection, Timber to timber

Bracket number	Nail number $n_{H,top}$	Nail number $n_{H,bottom}$	$F_{1,Rk}$ [kN] (purlin)	
			Timber	Steel
071 100 000 33x43x83x54x3,0	14,16	1,2,4,5,6,8,9,11,12,13	3,68	2,92

The table contains the characteristic values of the load carrying capacity for a purlin connection. Values must be halved for one joint per connection.

Table 7: Forces $F_{2,3}$, 2 Z-connectors / connection, Timber to timber

Bracket number	Nail number $n_{H,top}$	Nail number $n_{H,bottom}$	$F_{2,3,Rk}$ [kN] (purlin)	
			Timber	Steel
071 100 000 33x43x83x54x3,0	14,16	1,2,4,5,6,8,9,11,12,13	4,24	2,03

The table contains the characteristic values of the load carrying capacity for a purlin connection. Values must be halved for one joint per connection.

S 250 GD / Z275 Steel hold-downs

The hold-down's load-carrying-capacity results out of the smaller value according to Table 8 in dependence of the mode of failure. The load-carrying-capacity of single nail has to be multiplied by the number of nails.

The minimum nail's end and edge distances according to EN 1995 have to be provided. The load carrying-capacity of the hold-downs in concrete has to be proved separately (see EN 1992).

Table 8: Force F_1 Column, 1 hold-down / connection, Timber to concrete

Bracket number	dimensions [mm]			Load-carrying-capacity timber $F_{1,v,Rk}$ [kN]	Load-carrying-capacity steel - tension $F_{1,t,Rk}$ [kN]
	a	l	t		
071 091 000	40	202 + 42	2,0	$n \cdot 1,62$	17,8
071 092 000	40	302 + 42	2,0	$n \cdot 1,62$	17,8
071 093 000	40	402 + 42	2,0	$n \cdot 1,62$	17,8
071 191 000	40	204 + 44	4,0	$n \cdot 1,57$	35,6
071 192 000	40	304 + 44	4,0	$n \cdot 1,57$	35,6

The table contains the characteristic values of the load carrying capacity for a column connection. Values can be added in case of additional joints per connection.

If a wood-based panel interlayer with a thickness of not more than 26 mm is placed between the connector plate and the timber member, the lateral load-carrying capacity of the nail or screw, respectively, has to take into account the effect of the interlayer.

To obtain design values of $F_{1,t,Rk}$ (steel) the particular partial factor γ_{M2} according to EN 1993 has to be applied. To obtain design values of $F_{1,v,Rk}$ (timber) the particular partial factor γ_M according to EN 1995 has to be applied.

Definitions of forces, their directions and eccentricity

Forces - Beam to beam connection

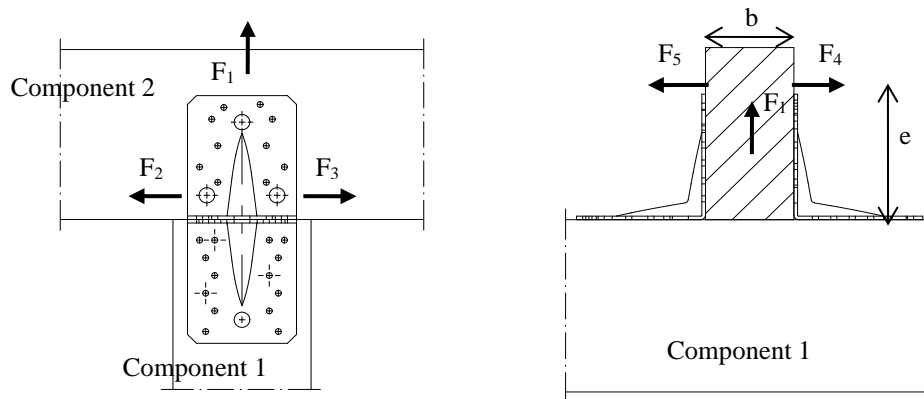

Fastener specification

Holes are marked with numbers referring to the nailing pattern in Annex A.

Double brackets per connection

The brackets must be placed at each side opposite to each other, symmetrically to the component axis.

Acting forces

- F_1 ($F_{1,t}$, $F_{1,v}$) Lifting force acting along the central axis of the joint.
- ($F_{1,c}$) Compressive force acting along the central axis of the joint.
- F_2 and F_3 Lateral force acting in the joint between the component 2 and component 1 in the component 2 direction
- F_4 and F_5 Lateral force acting in the component 1 direction along the central axis of the joint. If the load is applied with an eccentricity e , a design for combined loading is required.

Single bracket per connection

Acting forces

- F_1 Lifting force acting in the central axis of the bracket. The component 2 shall be prevented from rotation. If the component 2 is prevented from rotation the load-carrying capacity will be half of a connection with double brackets.
- F_2 and F_3 Lateral force acting in the joint between the component 2 and the component 1 in the component 2 direction. The component 2 shall be prevented from rotation. If the component 2 is prevented from rotation the load-carrying capacity will be half of a connection with double brackets.
- F_4 and F_5 Lateral force acting in the component 1 direction in the height of the top edge of component 2. F_4 is the lateral force towards the bracket; F_5 is the lateral force away from the bracket. Only the characteristic load-carrying capacities for brackets with ribs are given.

Wane

Wane is not allowed, the timber has to be sharp-edged in the area of the brackets.

Timber splitting

For the lifting force F_1 it must be checked in accordance with Eurocode 5 or a similar national Timber Code that splitting will not occur.

Combined forces

If the forces F_1 and F_2/F_3 or F_4/F_5 act at the same time, the following inequality shall be fulfilled:

$$\left(\frac{F_{1,d}}{F_{Rd,1}}\right)^2 + \left(\frac{F_{2,d}}{F_{Rd,2}}\right)^2 + \left(\frac{F_{3,d}}{F_{Rd,3}}\right)^2 + \left(\frac{F_{4,d}}{F_{Rd,4}}\right)^2 + \left(\frac{F_{5,d}}{F_{Rd,5}}\right)^2 \leq 1$$

The forces F_2 and F_3 or F_4 and F_5 are forces with opposite direction. Therefore only one force F_2 or F_3 , and F_4 or F_5 , respectively, is able to act simultaneously with F_1 , while the other shall be set to zero.

If the load F_4/F_5 is applied with an eccentricity e , a design for combined loading **for connections with double angle brackets** is required. Here, an additional force ΔF_1 has to be added to the existing force F_1 .

$$\Delta F_{1,d} = F_{4,d} / F_{5,d} \cdot \frac{e}{B}$$

B is the width of component 2.